

# A GUIDE TO LOW RESISTANCE TESTING

Understanding and Measuring Low Resistance to Ensure Electrical System Performance

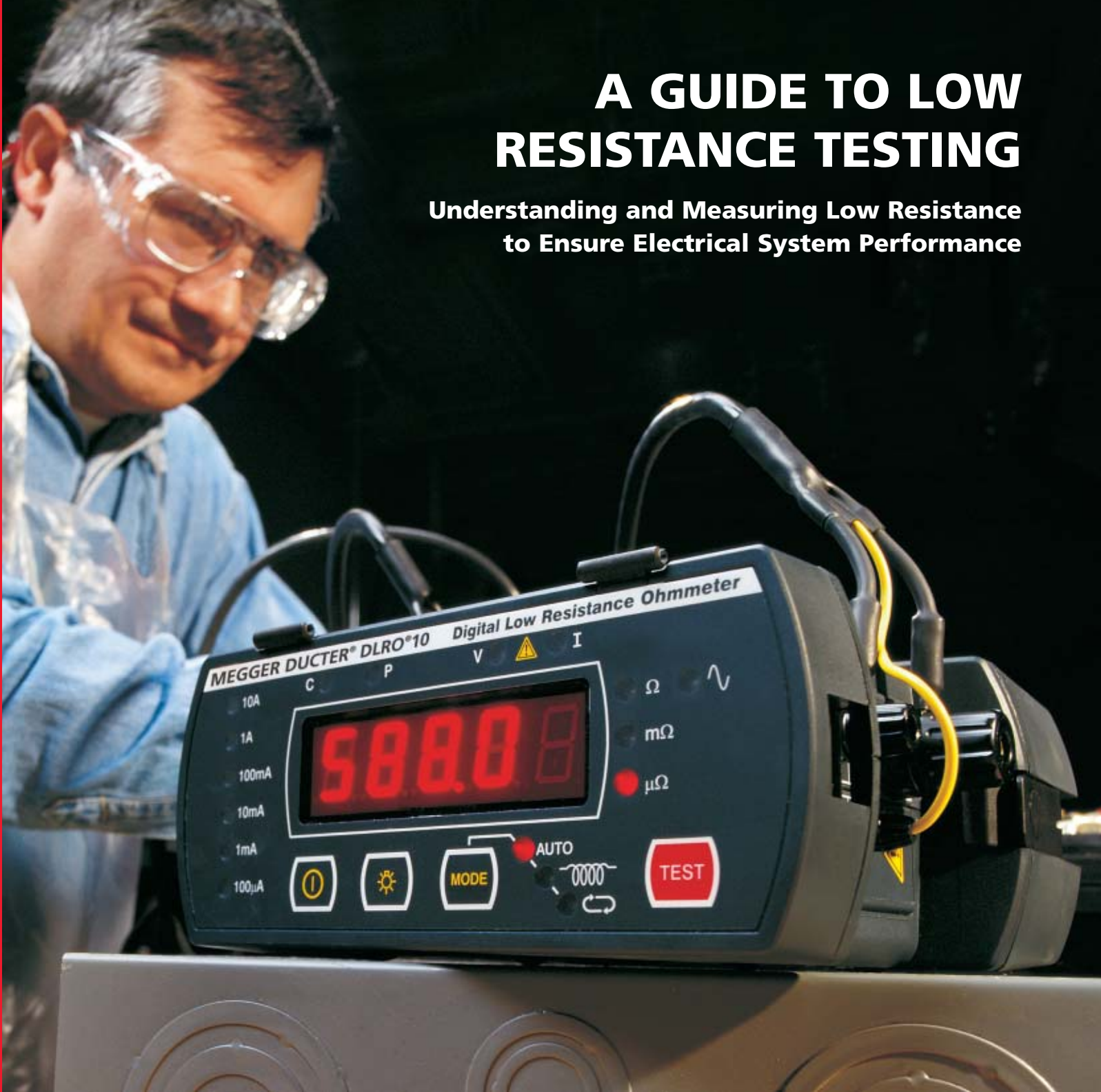

**Megger**

[WWW.MEGGER.COM](http://WWW.MEGGER.COM)

**Introduction** .....2

**Why Measure Low Resistance?** .....3

What is a Low Resistance Measurement? .....3

What Does the Low Resistance Measurement Tell the Operator? .....3

What Problems Create the Need to Perform the Test? .....4

Industries with Significant Resistance Problems ... 4

Specific Examples of Apparatus in Need of Low Resistance Testing .....4

    Motor Armature .....5

    Automotive Assembly .....5

    Power Generation and Distribution (high current joints, connections and bus bars) ... 5

    Transformer Testing .....5

    Uninterruptible Power Supply - Battery Straps ... 5

    Cement Plants and other Raw Material Processing Applications .....6

    Circuit Breakers .....6

    Aircraft Assembly .....7

    Strap and Wire Bonds between Rail Segments (Railroad Industry) .....7

    Graphite Electrodes .....7

    Welding Spot or Seam .....7

    Cable Reels .....7

**How do You Measure Low Resistance** ..... 8

2-Wire, 3-Wire and 4-Wire DC Measurements .....8

    Two-Wire Measurements .....8

    Three-Wire Measurements .....9

    Four-Wire Measurements .....9

DC vs. AC Testing .....9

How Does a Low Resistance Ohmmeter Operate? .10

Current Selection .....10

Probe and Lead Selection .....11

Low Range Testing .....11

Test on “Dead” Test Samples .....12

**Types of Testers/How to Choose** .....12

    Milli-Ohmmeter .....12

    10-A Micro-Ohmmeter .....12

    100+ A Micro-Ohmmeter .....12

    Transformer Ohmmeter .....13

    Lab Micro-Ohmmeter .....13

**Evaluation/Interpretation of Results** .....14

Repeatability .....14

Spot Readings/Base Expectations for Readings ... 14

Trending .....14

    Circuit Breakers .....15

    Stand-by Battery Back-up Systems .....15

**Appendices** .....16

Potential Sources of Error/Ensuring Quality Results .....16

    Test Leads/Probes .....16

    Accuracy Statements .....17

    Interference .....17

    Delivery of Stated Test Current Under Load ... 17

    Taking the Measurement at a Stable Plateau ... 17

Material Resistivity .....17

Effects of Temperature on Measured Resistance Values .....18

Effects of Humidity .....19

Background Noise Conditions, Current and Voltage .....19

Use and Misuse of Low Resistance Ohmmeters ... 19

Brief History of Low Resistance Ohmmeters .....20

Calibration .....20

Ingress Protection .....20

Various Test Modes .....22

    Models Designed in the 1970s and 1980s .....22

    Recently Designed 10 Amp Models .....22

Nominal versus Absolute Test Current Levels ... 22

Autoranging .....23

Transformer Testing .....23

Bar to Bar Testing .....24

Battery Strap Testing .....26

Wheatstone and Kelvin Bridges .....27

    Wheatstone Bridge .....27

    Kelvin Bridge .....27

Safety .....28

**Megger Products Overview** .....29

Front Cover  
 Low Resistance Ohmmeter shown being used to measure contact resistance of a low voltage molded case breaker.

**INTRODUCTION**

The quantitative study of electrical circuits originated in 1827, when Georg Simon Ohm published his famous book “Die galvanische Kette, mathematisch bearbeitet” in which he gave his complete theory of electricity. In this seminal work, he introduced the relationship or “Law” that carries his name:

$$\text{Resistance (R)} = \text{Voltage (E)} / \text{Current (I)}$$

At that time, the standards for Voltage, Current and Resistance had not been developed. Ohm’s Law expressed the fact that the magnitude of the current flowing in a circuit depended directly on the electrical forces or pressure and inversely on a property of the circuit known as the resistance. Obviously, however, he did not have units of the size of our present volt, ampere, and ohm to measure these quantities.

At this time, laboratories developed resistance elements, constructed of iron, copper or other available alloy materials. The laboratories needed stable alloys that could be moved from place to place to certify the measurements under review. The standard for the ohm had to be temperature stable and with minimum effects due to the material connected to the ohm standard.

In 1861, a committee was established to develop a resistance standard. This committee included a number of famous men with whom we are now familiar, including James Clerk Maxwell, James Prescott Joule, Lord William Thomson Kelvin and Sir Charles Wheatstone<sup>i</sup>. In 1864, a coil of platinum-silver alloy wire sealed in a container filled with paraffin was used as a standard. This was used for 20 years while studies were made for a more reliable standard. These studies continued as the old National Bureau of Standards (NBS), now known as the National Institute of Standards and Technology (NIST), controlled the standard for the “OHM.” Today the industry uses Manganin alloy because it has a low temperature coefficient so that its resistance changes very little with

temperature (see figure 1). The table below from Melvin B. Stout’s “Basic Electrical Measurements” highlights the key properties of Manganin.

The thermal emf against copper indicates the thermocouple activity of the material whereby a voltage is generated simply by connecting two different metals together. The goal is to minimize thermocouple activity as it introduces error into the measurement.

With the metric system, the measurements are in meters and the resistivity is determined for a one-meter cube of the material. However, more practical units are based on a centimeter cube. With the USA system, the resistivity is defined in ohms per mil foot. The wire diameter is measured in circular mils (0.001)<sup>2</sup> and the length in feet.

Figure 1 shows the temperature-resistance curve for Manganin wire at 20° C. For Manganin shunts, the 20° C curve shifts to 50° C, as this material will be operating at a higher temperature due to the The Manganin alloy was designed for use in coils used to perform stable measuring conditions at 20° C ambient room conditions. The alloy is modified for strips of material used in measuring shunts, which operate at a higher ambient, up to 50° C.

The purpose of this booklet is to help the engineer, technician or operator:

- Understand the rationale behind low resistance testing.
- Understand how to make a low resistance measurement.
- Understand how to select the proper instrument for the testing application.
- Understand how to interpret and use the results.

Composition Percent	Resistivity <sup>ii</sup>		Temperature Coefficient per °C	Thermal emf Against Copper μv/ °C
	Micro-ohms for cm Cube	Ohms for Cir. mil Foot		
Cu 84% Mn 12% Ni 4%	44 μΩ	264 Ω	*±0.00001°	1.7

\*Manganin shows zero effect from 20° to 30° C.

<sup>i</sup> Swoope’s Lessons in Practical Electricity; Eighteenth Edition; Erich Hausmann, E.E., ScD.; page 111

<sup>ii</sup> Swoope’s Lessons in Practical Electricity; Eighteenth Edition; Erich Hausmann, E.E., ScD.; page 118

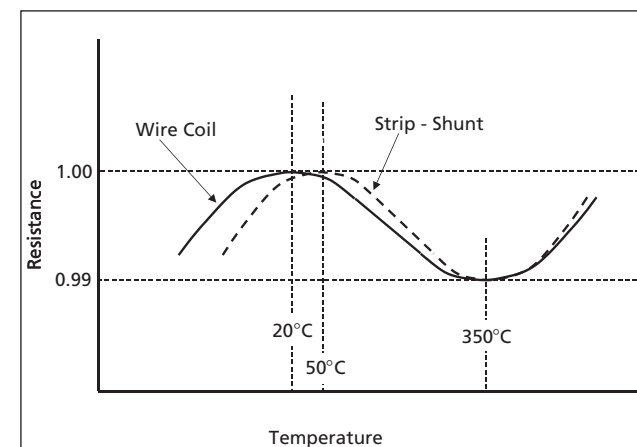

Figure 1: Qualitative Resistance-Temperature Curve for Manganin<sup>iii</sup>

**WHY MEASURE LOW RESISTANCE?**

Measuring low resistance helps identify resistance elements that have increased above acceptable values. The operation of electrical equipment depends on the controlled flow of current within the design parameters of the given piece of equipment. Ohm’s Law dictates that for a specified energy source, operating on V ac or V dc, the amount of current drawn will be dependent upon the resistance of the circuit or component.

In the modern age of electronics, increased demands are placed on all aspects of electrical circuitry. Years ago the ability to measure 10 milli-ohms was acceptable, but, in the present industrial electronic environments, the field test engineer is now required to make measurements which show repeatability within a few micro-ohms or less. These types of measurements require the unique characteristics of a low resistance ohmmeter’s four-wire test method, which is covered on page 9 in this booklet.

Low resistance measurements are required to prevent long term damage to existing equipment and to minimize energy wasted as heat. They indicate any restrictions in current flow that might prevent a machine from generating its full power or allow insufficient current to flow to activate protective devices in the case of a fault.

Periodic tests are made to evaluate an initial condition or to identify unexpected changes in the measured values, and the trending of this data helps indicate and may forecast possible failure conditions. Excessive changes in measured values point to the need for corrective action to prevent a major failure.

<sup>iii</sup> Basic Electrical Measurements; Melvin B. Stout; 1950; page 61

When making field measurements, the operator ought to have reference values that apply to the device being tested (the manufacturer should include this information in the literature or name-plate supplied with the device). If the tests are a repeat of prior tests, then these records may also be used to observe the range of the anticipated measurements.

If, when conducting tests, the operator records the results and the conditions under which the tests were performed, the information becomes the beginning of a database that can be used to identify any changes from fatigue, corrosion, vibration, temperature or other condition that may occur at the test site.

**What is a Low Resistance Measurement?**

A low resistance measurement is typically a measurement below 1.000 ohm. At this level it is important to use test equipment that will minimize errors introduced by the test lead resistance and/or contact resistance between the probe and the material being tested. Also, at this level, standing voltages across the item being measured (e.g. thermal emfs at junctions between different metals) may cause errors, which need to be identified.

To allow a measurement to compensate the errors, a four-terminal measurement method is employed with a reversible test current and a suitable Kelvin Bridge meter. Low resistance ohmmeters are designed specifically for these applications. In addition the upper span on a number of these meters will range into kilohms, which covers the lower ranges of a Wheatstone Bridge (please see the appendix for a discussion of the Wheatstone and Kelvin Bridge methods). The lower range on many low resistance ohmmeters will resolve 0.1 micro-ohms. This level of measurement is required to perform a number of low range resistance tests.

**What Does the Low Resistance Measurement Tell the Operator?**

Resistance (R) is the property of a circuit or element that determines, for a given current, the rate at which electrical energy is converted to heat in accordance with the formula  $W=I^2R$ . The practical unit is the ohm. The low resistance measurement will indicate to the observant operator when degradation has or is taking place within an electrical device.

Changes in the value of a low resistance element are one of the best and quickest indications of degradation taking place between two contact points. Alternatively, readings can be compared to “like” test specimens. These elements include

rail bonds, ground bonds, circuit breaker contacts, switches, transformer windings, battery strap connections, motor windings, squirrel cage bars, bus bar with cable joints and bond connections to ground beds.

The measurement will alert the operator to changes having taken place from the initial and/or subsequent measurements. These changes can occur from a number of influences including temperature, chemical corrosion, vibration, loss of torque between mating surfaces, fatigue and improper handling.

These measurements are required on a regular timed cycle in order to chart any changes taking place. Seasonal changes may be evident when summer and winter data are reviewed.

**What Problems Create the Need to Perform the Test?**

Assuming a device has been correctly installed in the first place, temperature, cycling, fatigue, vibration and corrosion all work to cause the gradual degradation of the resistance value of an electrical device. These influences build up over a period of time until a level is reached at which the device no longer operates correctly. The critical degrading factor will be determined by the application.

Environmental and chemical attacks are relentless. Even air will oxidize organic materials while the ingress of moisture, oil and salt will degrade connections even more rapidly. Chemical corrosion can attack the cross sectional area of an element, reducing the area while increasing the resistance of the component. Electrical stresses, particularly sustained overvoltages or impulses, can cause welds to loosen. Mechanical stress from vibration during operation can also degrade connections, causing resistance to rise. These conditions result in excessive heating at the location when the component is carrying the rated current, based on the formula  $W=I^2R$ . For example:

6000 A across a 100  $\mu\Omega$  bus = 3600 Watts.

6000 A across a 1  $\mu\Omega$  bus = 36,000 Watts, which will result in excessive heating.

If left unattended, these types of problems can lead to failure in the electrical system containing the affected components. Excessive heating will ultimately result in failure due to burnout, which may open an energized circuit.

Backup battery power supplies provide a good practical example of how degradation can occur under normal operating conditions. Changes in current flow cause expansion and contraction of the terminal connections, causing them to loosen or corrode. Additionally, connections

are exposed to acid vapors, causing further degradation. These conditions result in a decrease in the surface-to-surface contact area with an associated increase in surface-to-surface contact resistance, ultimately causing excessive heating at the junction.

**Industries with Significant Resistance Problems**

Industries that consume vast amounts of electrical power must include low resistance ohmmeter measurements in their maintenance operations. Not only does abnormally high resistance cause unwanted heating, possibly leading to danger, but it also causes energy losses which increase operating costs; in effect you are paying for energy which you can't use.

In addition, there are industries that have critical specifications on bond connections to ensure solid connections to "ground beds." Poor connections reduce the effectiveness of the ground bed and can cause significant power quality-related problems and/or catastrophic failure in the event of major electrical surge. A number of sub-assembly operations supply components to aircraft manufacturers that specify low resistance connections to the airframe. Strap connections between cells on a power back-up battery system also require very low resistance. A general list of industries include:

- Power generation and distribution companies
- Chemical plants
- Refineries
- Mines
- Railroads
- Telecommunications companies
- Automotive manufacturers
- Aircraft manufacturers
- Anyone with UPS battery back-up systems

**Specific Examples of Apparatus in Need of Low Resistance Testing**

As we have shown, low resistance ohmmeters have application in a wide range of industries and can help identify a number of problems that could lead to apparatus failure. In general manufacturing industries, motor windings, circuit breakers, bus bar connections, coils, ground bonds, switches, weld joints, lightning conductors, small transformers and resistive components all require low resistance testing.

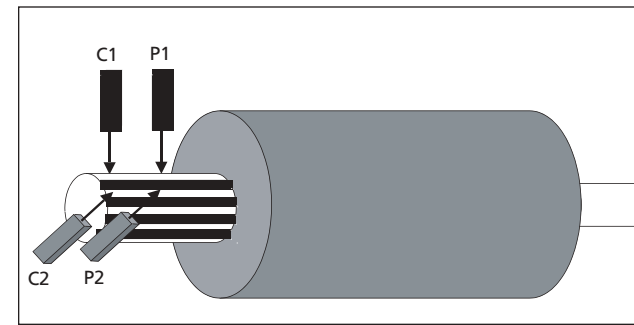

Figure 2: Bar to Bar Testing on DC Motor Rotor

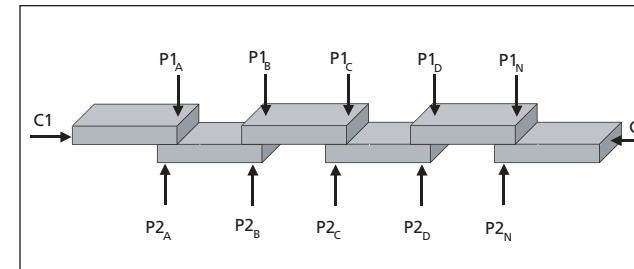

Figure 3: Bus Bar Connections

Following are some of the more typical applications.

**Motor Armature**

Armature windings can be tested to identify shorting between adjacent coils or conductors. Squirrel cage bars in the rotor can separate from the end plates, resulting in loss of performance. If a motor appears to be losing power, a low resistance test should be performed. Alternatively, tests can be made when bearings are being replaced at a periodic or annual shutdown.

Bar to bar testing on dc motor rotors is performed to identify open or shorted coils (see Figure 2). These tests are performed with spring loaded hand probes. This is a dynamic method to determine the conditions of the windings and the soldered connections to the riser on the commutator segments. When test data is reviewed periodically, the effects of overheating due to excessive temperature rise can be identified.

**Automotive Assembly**

Cable leads in a "robot" spot welder can work-harden through continual flexing. Eventually fatigue can occur causing strands to break. This condition results in a high lead resistance with loss of power to the weld, producing a poor spot-weld (nugget) or even complete failure of the machine.

**Power Generation and Distribution (high current joints, connections and bus bars)**

Bus bars in a power system consisting of lap joints and other connections, are used to deliver current to the elements in the system. These bolted connections can be degraded by vibration and corrosion. (See Figure 3.) The bolts are stressed to a specific tightness (torque), and the quickest and most economical way to determine the quality of the connection is to measure the resistance across the joint. The operator should have historical data to make the determination on the suitability of the connection. If left uncorrected, loss of power and/or excessive heating could lead to a meltdown at the connection.

**Transformer Testing**

Transformer winding tests are performed in the factory and then periodically in the field. The factory test is performed at ambient temperature. A second factory test is a heat run to verify that, at rated power, the resistance of the windings remains within its designed temperature rise characteristics.

Large transformers have "taps" on both the primary and secondary windings. The condition of the taps requires verification, since the secondary taps are operated daily and are exposed to excessive wear and vibration as the power distribution system balances the load carried on the various circuits. The taps on the primary side are critical to major adjustments in the power distribution and should be tested to ensure that a low resistance connection is available for the new power condition. Tap connections can corrode when not in use and may overheat due to the high current (which can result in a fire).

**Uninterruptible Power Supply - Battery Straps**

On series connected industrial batteries, straps (lead coated copper bars) are secured to the posts on adjacent batteries, (+) to (-), with stainless steel bolts. These surfaces are cleaned, greased and tightened to a preset torque value. As noted previously, they are subject to vibration, chemical corrosion and heat due to the charging and high current discharges associated with the application. The quickest and best way to determine the quality of the connections is to measure the resistance between the two adjacent battery terminals (see Figures 4 and 5). This is the only field application in which the operator makes measurements on an energized system. Please see the appendix for more detail on battery strap testing.

Please note that there are various levels of “float current” in a battery system and the test procedure must account for this current flow. A test is performed with the test current added to the float current and a second test is made with the test current opposed to the float current. These two measurements are averaged to determine the “ohmic” value of the connection.

Standard procedures require measurements on a regular schedule, as past experience has determined that battery straps are one of the weakest elements in the operation of a battery system. When not attended to on a regular test program, high resistance connections can develop. This situation can result in the battery being unable to deliver sufficient current when called for, or when combined with current surge and hydrogen gas evolved from the battery cells, can cause a fire in the battery system, destroying the UPS.

Carrier strips “carry” the plates in a cell. The plates are suspended from the carrier strips into the liquid in the cell. If the resistance of the terminal to carrier strip welds is too high, the battery’s ability to carry current is limited. In addition to measuring strap resistance, a low resistance ohmmeter can also be used to measure the quality of these welds (see Figure 6).

**Cement Plants and other Raw Material Processing Applications**

The electrical system at a cement plant or other raw materials processing facility includes motors, relays, disconnect switches, etc. The testing of these power-carrying elements as part of a regular program or when major retrofits take place is critical to the ongoing operation of the plant. The quality of the current connections can identify weak elements or connections in the system. Note that cement dust is chemically active (corrosive) and will attack metallic connection.

**Circuit Breakers**

Due to arcing at the circuit breaker pads, carbonized layers will build up and the live contact area will reduce or become pitted, leading to increased resistance and heating. This situation reduces the efficiency of the breaker and can lead to failure on an active transmission system resulting in the loss of a substation. When planning a test, the operator must be aware of IEC62271-100 and ANSI C37.09 for test current requirements. When testing large oil circuit breakers, the best instrument is one that ramps up current, holds it for a period of time and then ramps down. This test method reduces the

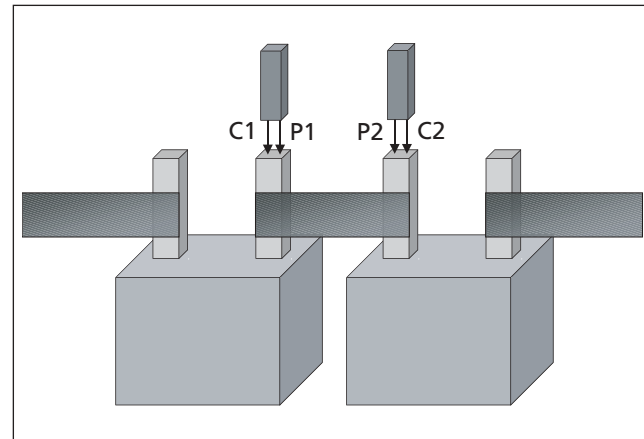

Figure 4: Single Strap with Two Contact Surfaces

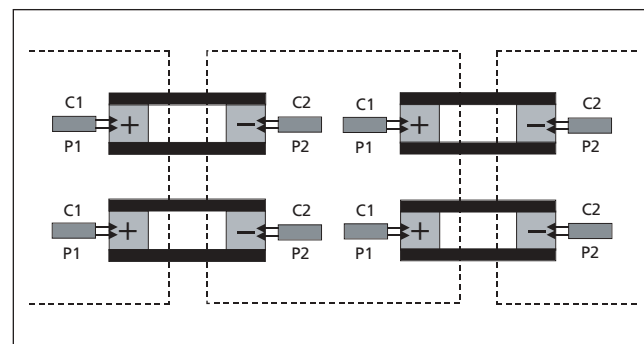

Figure 5: Parallel Straps on a Large Battery Complex

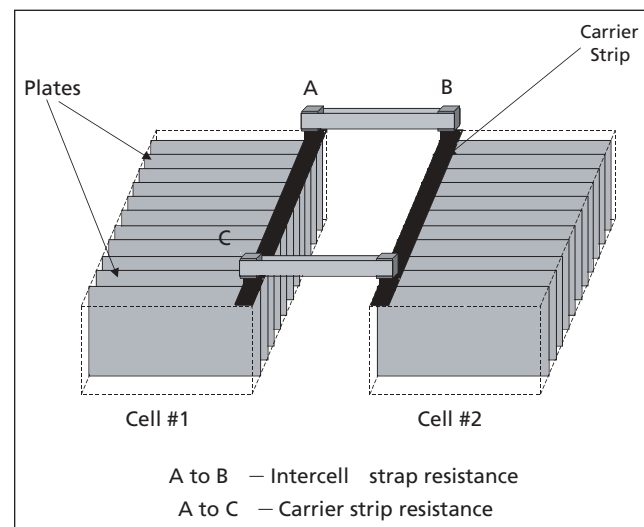

Figure 6: Measuring Carrier Strip Resistance

magnetizing, which would otherwise be created by the sudden switching on and off of the test current. This can result in inaccurate “CT” measurements when the system is returned to normal ac operation.

Care should be taken when making a measurement across a CT as high dc currents may saturate the CT, desensitizing it to potential faults. Also, ripple on the test current may cause circuit breakers to trip. Careful positioning of the current probes should prevent this happening, and the ripple present on the current waveform may be minimized by separating the test leads.

**Aircraft Assembly**

Bond testing of all the main frame electrical and mechanical connections is required to ensure a stable “ground plane” within an aircraft. These physical “bond” connections provide a uniform path for static electricity to be discharged to the wicks on the trailing edge of the wings and tail assembly. This path reduces the chance of lightning damaging the avionics in the event of a lightning strike situation. Over time, the bonding of static wicks, antenna, control linkage and battery terminals should be inspected. The integrity of a welded exhaust system should also be verified and documented. In normal operations, excessive static electricity will not effect the operation of most navigation and communications systems. The best (lowest) resistance connections will improve the performance of such systems.

**Strap and Wire Bonds between Rail Segments (Railroad Industry)**

In the railroad environment, bonds are exposed to vibration as the wheels pass over the rails (each click-clack causes vibration across the interface bonding the strap to the rail). These bonds are part of the control system which tells the operator the location of different trains. Within the rail system, a telephone system uses the rail conductors to communicate. The resistance of these bonds is critical to the performance of the control system. In systems that use three rails, the third rail is the active source of power for the engine, and power lost across a high resistance bond (such as a poor Cadweld joint) reduces the efficiency of the transit system. The operator can select a five-foot section of track without a bond, make a measurement and then measure a five-foot section with a bond to determine the quality of the connection. As a rule of thumb, these measurements should be within a few micro-ohms (or  $\pm 5\%$ ).

**Graphite Electrodes**

Graphite electrodes have a negative temperature characteristic. (As the temperature of the element increases the resistance measurement will decrease.) Graphite slugs are extruded as large diameter cylinders and may be up to six feet in length. One of the applications for these large slugs is in aluminum refineries where high currents (150,000 A) are used to reduce bauxite ore to high-grade aluminum.

Low resistance testing is done as a quality control step to verify the density of the graphite extrusion. Due to the size of the electrodes, this test requires a special test fixture to introduce the test current across the surface of the ends, ensuring a uniform current density through the volume of the sample. The potential probes are then connected across a known length of the sample to determine the “ohms per unit length” (see Figure 7 on the following page).

**Welding Spot or Seam**

The quality of a spot weld can be determined by measuring the resistance across the joined materials. The quality of a seam weld can be determined by a series of tests along the weld seam. Readings should remain within a narrow band of values. An increase and then drop in readings is an indication that the uniformity of the weld is out of specification. To make the measurement properly, the operator should fabricate a fixture to keep the probes in a fixed relationship. Readings are then taken at a number of points across the weld seam and plotted (see Figure 8). These measurements are normally in the micro-ohm region and special care is required in the design of the test fixture.

**Cable Reels**

A reel of insulated copper wire may have a tag indicating the wire gauge along with the ohms per unit length. When wire remains on the reel after partial utilization, the remaining length can be calculated by measuring the resistance of the wire and making a calculation using the ohms per length specification (see Figure 9).

Alternatively, if the tag has been destroyed, the operator can cut off a known length of wire, measure that sample and determine the ohms per length. This value can then be used with the reading taken when measuring the balance of wire on the reel to calculate the remaining length. The temperature of the reel of cable will be approximately the same as the temperature of the sample. Though the internal temperature of the reel may be slightly different, a reasonable estimate of the remaining length of cable can be calculated.

If the operator reviews the temperature charts on pages 18 and 19 in this book, an estimate of the inaccuracy can be determined. This method also applies to aluminum and steel wires as long as the wire has an insulating coating to prevent shorting between adjacent loops of wire.

**HOW DO YOU MEASURE LOW RESISTANCE**

**2-Wire, 3-Wire and 4-Wire DC Measurements**

Why do we have resistance measuring instruments, some with only two test leads, some with three and even some with four test leads? The answer depends on the degree of information required from the measurement, and the magnitude of the resistance being measured. Resistance readings cover a wide range of values from micro-ohms into the thousands of meg-ohms region. Figure 10 shows the measurement range in which each type of instrument performs best.

**Two-Wire Measurements**

Two-wire testing is the simplest method and it is used to make a general assessment of a circuit element, conductor or the routing of a conductor in a circuit. The two-wire lead configuration is most familiar to many operators as it is the configuration used on most multimeters. It is generally used when the probe's contact resistance, series lead resistance or parallel leakage resistances do not degrade the quality of the measurement beyond a point acceptable to the operator.

The measured value will include the test lead wire resistance and contact probe resistance values, which will affect the measurement by adding some tens of milli-ohms to the actual resistance. In most instances this will make little practical difference to the measured value, but when the measurement is below 1.000 ohm the two-wire method can easily introduce an error, which could be several percent, into the measured resistance value.

The specifications on some hand-held meters indicate a 200 milli-ohm range with one milli-ohm sensitivity. The lead resistance may be zeroed out, but that leaves the uncertainty of the contact resistances, which can change with each measurement. Contact resistance values may be in the 35 milli-ohm range at each probe and can vary with the temperature of the material under investigation.

The two-wire test method is best used for readings above 10.00 ohms up to 1.0 to 10.0 megohms.

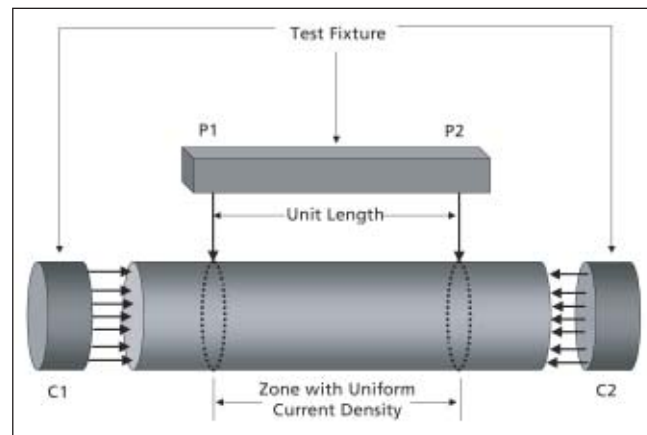

Figure 7: Testing Graphite Slugs for Uniform Density (ohms/inch)

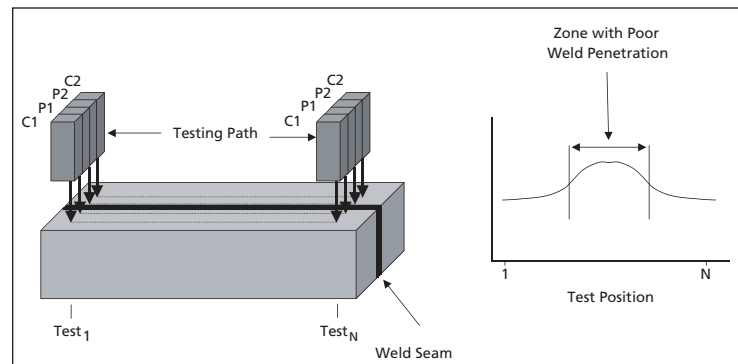

Figure 8: Series of Measurements Across a Weld Seam

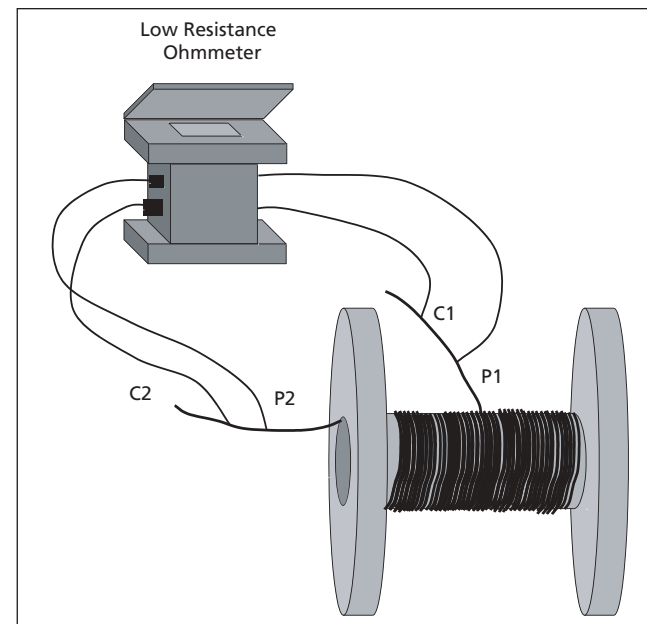

Figure 9: Determining the Remaining Length of Cable on a Reel

**Three-Wire Measurements**

Three-wire dc testing is reserved for very high resistance and is typically used for measurements above 10.0 megohms. We normally associate this type of testing with diagnostic insulation resistance. The test method uses a third test lead as a guard, and allows for resistances in parallel with the test circuit to be eliminated from the measurement. This parallel resistance is usually considerably lower than the insulation resistance being measured. In fact it may, in severe cases, effectively short out the insulation resistance such that a meaningful measurement cannot be carried out without the use of a guarding circuit.

This test method is described and illustrated in the Megger booklets "A Stitch in Time..." and "A Guide To Diagnostic Insulation Testing Above 1 kV."

**Four-Wire Measurements**

Four-wire testing is the most accurate method when measuring circuits below 10.00 ohms as this method eliminates errors due to lead and contact resistances. This is the test method associated with low resistance ohmmeters. Four-wire dc measurements uses two current and two potential leads (see Figure 11). The four-wire dc measurement negates the errors due to the probe lead wire and any contact resistance values in the final reading, ensuring more accurate measurements.

**DC vs. AC Testing**

The issue here is the selection of the correct type of test current. A dc instrument should be used when trying to measure the pure resistance of a circuit or device. An ac instrument is used for applications such as ground bed testing or impedance testing.

A special impedance meter is used to perform tests on industrial batteries. The word impedance is used to indicate a measurement comprised of a resistance and reactance, which can be either an inductive or capacitive component. These measurements are conducted as

part of a battery maintenance program; typically a low resistance ohmmeter is used to perform strap connection verification tests.

Three or four-wire ac measuring systems are used to perform tests on "ground beds" with special frequencies that exclude measurement errors from 50/60 Hz ground currents. The use of ac prevents the test current polarizing ions in the soil, thereby changing the conditions and thus the measured values. This is an area of interest to the electrical power distribution and telecommunication fields. The low ground resistance path is required for maintaining the potential of the ground wire to the "earth" potential. Electrical performance of the power system minimizes shock hazards as a path to ground is made available for the energy from lightning and other static voltages that may affect the power control system. The same conditions pertain to the telephone systems, as high resistance grounds can cause excessive noise on the voice and data links. Please see the Megger booklet "Getting Down to Earth" for more information on ground resistance testing. Both of these industries require not only low ground bed resistance but also low resistance "ac/dc bonds" between the ground bed and the active circuits.

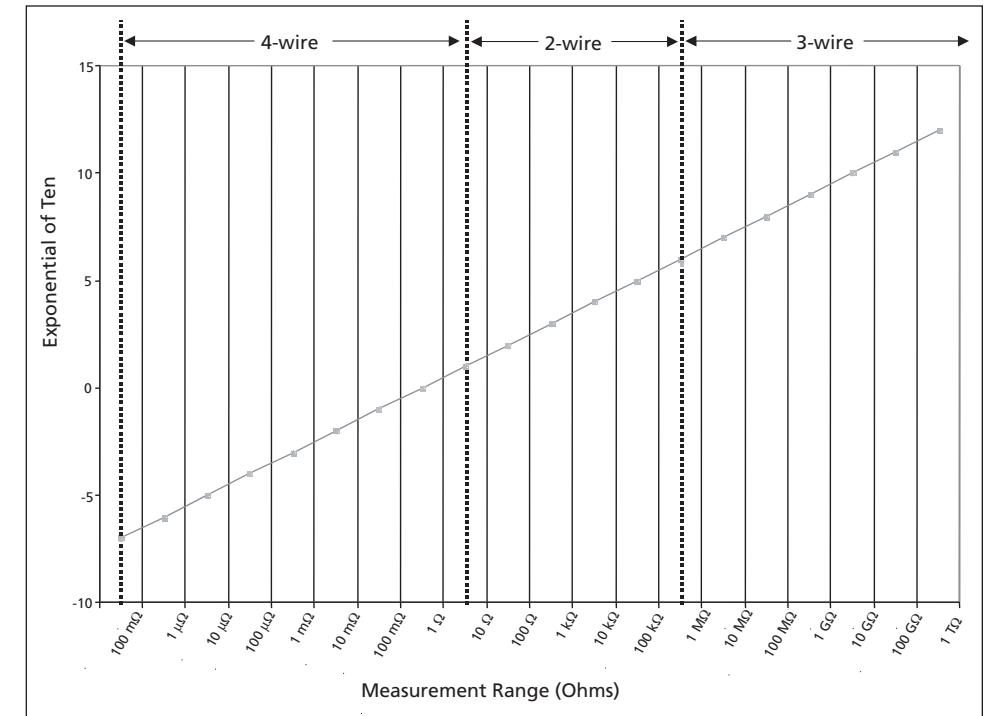

Figure 10: Selection of Optimum Measuring Technique

**How Does a Low Resistance Ohmmeter Operate?**

A low resistance ohmmeter uses two internal measuring circuits. The supply injects a current into the test sample through two leads, usually identified as C1 and C2, and the magnitude of the current is measured. Concurrently, two probes (normally referred to as P1 and P2) measure the potential across the sample. The instrument then performs an internal calculation to determine the resistance of the test sample.

Why does this approach result in a measurement that is independent of lead resistance and contact resistance?

We have represented the complete measurement circuit in Figure 12. Current is injected into the item under test via leads C1 and C2. The current that flows will be dependent upon the total resistance of this loop and the power available to push the current through that resistance. Since this current is measured, and the measured value is used in subsequent calculations, the loop resistance, including the contact resistance of the C1 and C2 contacts and the lead resistance of C1 and C2, does not have an effect on the final result.

From Ohm's Law, if we pass a current through a resistance we will generate a voltage across the resistance. This voltage is detected by the P1 and P2 probes. The voltmeter to which these probes are connected internally has a high impedance, which prevents current flowing in this potential loop. Since no current flows, the contact resistance of the P1 and P2 contacts produces no voltage and thus has no effect on the potential difference (voltage) detected by the probes. Furthermore, since no current flows through the P leads their resistance has no effect.

A high current output is one of the qualifying characteristics of a true low resistance ohmmeter. Generic multimeters do not supply enough current to give a reliable indication of the current-carrying capabilities of joints, welds, bonds and the like under real operating conditions. At the same time, little voltage is required, as measurements are typically being made at the extreme low end of the resistance spectrum. Only the voltage drop across the measured resistance is critical, and it is measured at the millivolt level.

Good instruments alert the operator of open circuit conditions on the test leads while a few models have automatic range selection.

**Current Selection**

Depending on the instrument chosen, the current selection can be either manual or automatic. The operator should select the highest current suitable for the test to provide the best signal to noise ratio for the measurement. On instruments that offer current levels in excess of 10 amps, care is required to minimize any heating of the sample that would itself cause the resistance of the sample to change.

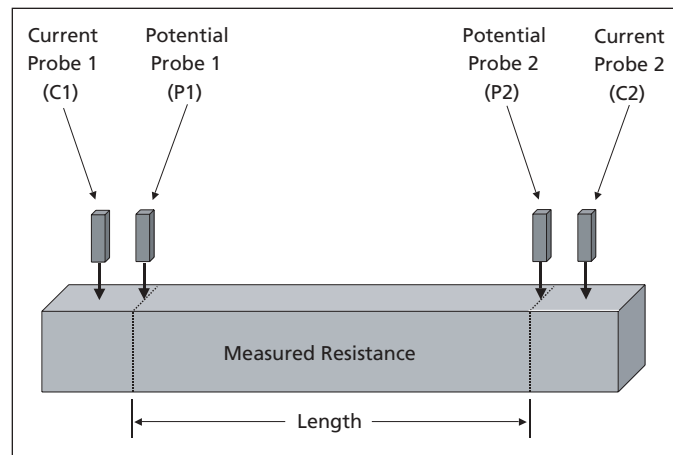

Figure 11: Simplified Example of a 4-Wire Measurement

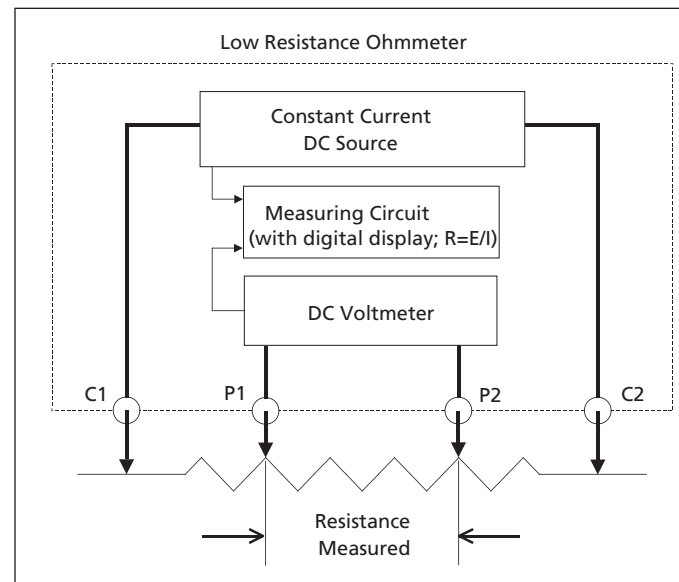

Figure 12: Basic Operation Diagram

Instruments designed for circuit breaker testing have much higher current characteristics and the operator must be careful when setting the test current level. Instruments designed specifically for transformer testing have a special high-voltage power level at the beginning of the test to saturate the winding. These units then switch to a lower constant current mode to measure the winding on the transformer.

**Probe and Lead Selection**

The potential and current leads are either connected separately or to a probe. When probes are used the potential connection is identified with a "P." The connections are placed in contact with the sample so that the P-identified contacts or leads are positioned towards each other. The current contacts are then positioned outside or away from the potential connections. This causes the current to flow with a more uniform current density across the sample being measured.

For the more rigorous tests, separate test leads are used and the current connections are positioned away from the potential connections by a distance that is 1½ times the circumference of the sample being measured. ASTM Standard B193-65 provides guidelines for making a measurement that will establish uniform current density. This standard suggests separating the current probes from the potential probes by 1½ times the cross sectional perimeter of the test specimen. Figure 13 shows a test being made to the standard on a cylindrical test item.

The use of probes, Kelvin Clips, or C-clamps will meet most field requirements as the operator should be making repetitive measurements under the same conditions. The sharp points on the probes should leave a mark on the specimen for future testing. In some situations a marker pen can indicate the test area and the probe positions will be identified by the probe indents.

Leads are available in a number of lengths to meet different field application requirements. The probe selection is made from separate current and potential leads with clips to connect to the test sample. Helical spring point probes have both potential and current probes in the same handle. The "P" identification on the probe identifies the position on the sample at which the measurement is taken. This probe arrangement provides a practical method when making repetitive measurements (ideal when testing strap connections in UPS battery supply systems).

Kelvin Clips and C-clamps have the current and potential connections 180° from each other, providing separate current and potential connections. The size of the terminal connection determines which one to select. See Figure 14 for the different probe/lead configurations.

Note: The order of connection of potential and current clips is not important. However, never connect the potential clip to the current clip as this will cause an error in the measurement due to the voltage drop at the current connection interface at the sample.

**Low Range Testing**

When measuring on the extreme edge of precision and sensitivity, factors become significant that would be too small to be of consequence in conventional testing. In low resistance testing, thermal emfs (electromotive forces) can produce voltage gradients across the test sample. Although only on the milli-volt level, and of little or no influence on common multimeter tests, these can cause fluctuations of several digits. Such instability defeats the purpose of a high-precision measurement. In addition, alternating current interference can be induced by nearby electric or magnetic fields, or may be present from the float charge on standby battery systems, or through leaky switches, electrical imbalance and so on.

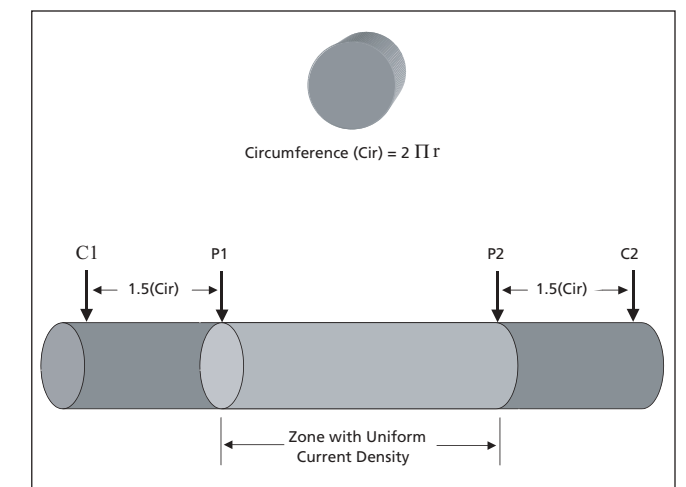

Figure 13: ASTM Standard B193-65

This problem is readily overcome, however, by taking readings in forward and reverse polarity and then averaging them. Some models accomplish this with a manually operated reversal switch, while others perform the two measurements automatically, then display the average reading. If unidirectional measurement is desired to save time (as in testing battery straps), the tester may have an override function. Another sophisticated technique automatically measures the magnitude and slope of thermal emfs and subtracts from the displayed reading.

**Test on Dead Test Samples**

As a general safety measure, normal testing should always be performed on de-energized samples. Special training and equipment are required to perform tests on energized circuits. Internal fused input circuits are designed into a few instruments that will protect the instrument if inadvertently connected to an energized test sample. The low input impedance of the current supply internal to general instruments becomes a willing current sink when connected across a live circuit.

**TYPES OF TESTERS/HOW TO CHOOSE**

**Milli-Ohmmeter**

As the name implies, a milli-ohmmeter is less sensitive than a micro-ohmmeter, with measurement capability in the milli-ohm rather than micro-ohm range (minimum resolution of 0.01 milli-ohm). This type of instrument is normally used for general circuit and component verification. Milli-ohmmeters also tend to be less expensive than micro-ohmmeters, making them a good choice if measurement sensitivity and resolution are not critical. The maximum test current is typically less than two amperes and as low as 0.2 amperes.

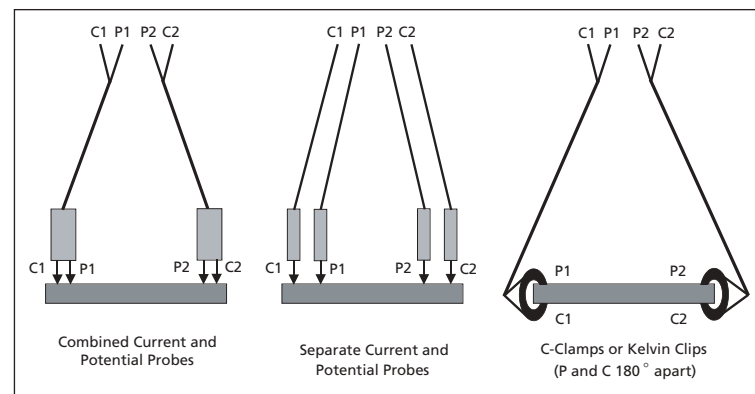

Figure 14: Probe/Lead Configurations

**10-A Micro-Ohmmeter**

The field portable micro-ohmmeter with a 10-amp maximum test current is the “work-horse” instrument for most operators because it covers the majority of field applications. The 10-amp output not only provides a comfortable and suitable test current through the test sample to make the measurement, but also allows for reduced weight and improved battery operation.

The best 10-amp micro-ohmmeters offer measurements from 0.1 micro-ohm to 2000 ohms with a best resolution of 0.1 micro-ohm at the low end of the range and accuracy of ±0.2%, ±0.2 micro-ohms. On some instruments, different measurement modes may be selected which address different types of testing conditions. Measurement modes could include manual, automatic or continuous testing, or a high power test for large windings.

Following is a selected list of key dc resistance measurement applications for 10-amp micro-ohmmeters.

- Switch and contact breaker resistance
- Bus bar and cable joints
- Aircraft frame bonds and static control circuits
- Welded joint integrity
- Intercell strap connections on battery systems
- Resistive components (quality control)
- Small transformer and motor winding resistance
- Rail and pipe bonds
- Metal alloy welds and fuse resistance
- Graphite electrodes and other composites
- Wire and cable resistance

- Transmitter aerial and lightning conductor bonding

**100+ A Micro-Ohmmeter**

According to IEC62271-100, testing the contact resistance of high voltage ac circuit breakers calls for a test current with any convenient value between 50 A and the rated normal current. ANSI C37.09 specifies that the test current should be a minimum of 100 A. Most electrical utilities prefer to test at higher currents, as they believe this is more representative of working conditions.

Field portable micro-ohmmeters are available that can deliver anywhere from 100 A up to 600 A (subject to the load resistance and supply voltage). The best instruments have measurement resolution to 0.1 micro-ohm and offer variable test current to address a wider range of applications. By testing at 10 A and then at a higher current, the operator can get a better understanding of the maintenance requirements for the circuit breaker.

In addition to circuit breakers, electrical utilities and testing companies use higher current micro-ohmmeters on other high voltage apparatus, including:

- Cables
- Cable joints
- Welds
- Bus bars
- Switchgear in general

Operators using 100+ A micro-ohmmeters should be aware of certain technical issues related to testing at high currents. Some operators have indicated they perform a 10 A test and then see improved resistance readings with 100+ A test currents. This difference in the measurements raises the question of whether there is a need for additional maintenance. A strict reading of Ohm’s Law does not indicate the need for the higher current to perform the measurement. In the equation  $R = V/I$ , the magnitude of the current is not defined. Is this a situation where the high current is blasting contaminants away from the contacts, and at the same time welding the contacts together? The operator should be aware that they may be masking a potential problem in a power distribution system and avoiding necessary maintenance.

Operators should also be aware that high current meters are intended to be used at high currents. Their accuracy may reduce considerably at low currents, particularly when measuring small resistances.

**Transformer Ohmmeter**

The transformer ohmmeter is designed specifically for problems found in measuring transformer windings and tap changers (discussed in more detail in the appendix). Some instruments include dual meters with independent range controls such that the primary (high resistance) and secondary (low resistance) windings of a transformer may be measured at the same time.

The transformer ohmmeter is a multi-current device, has measurement resolution to 1 micro-ohm and is used both in factory tests and for field operating verification.

Operation of the transformer ohmmeter is sometimes enhanced by connecting the test current through both windings with opposite polarity, thus providing the fastest test time (the mutual inductance between the windings is minimized). This current connection operation is used on wye to wye, wye to delta and delta to delta transformers. The ability to measure primary and secondary windings at the same time also speeds up the testing time.

The power supply is often designed to deliver the energy to saturate the winding and then provide a stable level of test current. The test set should also be able to test the windings and contact resistance on tap-changers with make-before-break contacts and voltage regulators. Tap-changers are the most vulnerable part of the transformer and face more failures and outages than any other component. Frequent testing is required to ensure proper and reliable operation.

A transformer ohmmeter is used to:

- Verify factory test readings.
- Help locate the presence of defects in transformers, such as loose connections.
- Check the make-before-break operation of on-load tap-changers.
- Perform “heat runs” to determine the internal temperature changes, via the winding resistance, that occur under rated current conditions.  
(See the Table for Copper - Temperature/ Resistance Relationship on the following page.)

Additional field test methods are noted in the appendix.

**Lab Micro-Ohmmeter**

Lab-style micro-ohmmeters are designed for measuring resistance components and use low pulsed currents (0.01 A – 1 A), with ranges from 199.9 micro-ohms to 1999 ohms. The pulses (+) and (-) allow the meter to eliminate errors due to thermal emf across the test sample. These types of instruments are not intended for measuring inductive circuits. Due to the low test current the operation in the field is limited as the signal to noise condition will reduce the sensitivity of the measurement.



**EVALUATION/INTERPRETATION OF RESULTS**

**Repeatability**

A good quality low resistance ohmmeter will provide repeatable readings within the accuracy specifications for the instrument. A typical accuracy specification is ±0.2% of reading, ±2 lsd (least significant digit). For a reading of 1500.0, this accuracy specification allows a variance of ±3.2 (0.2% x 1500 = 3; 2 lsd = 0.2).

Additionally, the temperature coefficient must be factored into the reading if the ambient temperature deviates from the standard calibration temperature.

**Spot Readings/Base Expectations for Readings**

Spot readings can be very important in understanding the condition of an electrical system. The operator should have some idea of the level of the expected measurement based on the system's data sheet or the supplier's nameplate. Using this information as a baseline, variances can be identified and analyzed. A comparison can also be made with data collected on similar equipment.

As noted, the data sheet or nameplate on a device should include electrical data relevant to its operation. The voltage, current and power requirements can be used to estimate the resistance of a circuit, and the operating specification can be used to determine the allowed change in a device (for example, with battery straps, connection resistances will change with time). Various national standards provide guidance for periodic test cycles.

The temperature of the device will have a strong influence on the expected reading. As an example, the data collected on a hot motor will be different from a cold reading at the time of the installation. As the motor warms up, the resistance readings will go up. The resistance of copper windings responds to changes in temperature based on the basic nature of copper as a material. A more detailed review of temperature effects is covered in the appendix. Using the nameplate data for a motor, the expected percentage change in resistance due to temperature can be estimated using the table shown to the right for copper windings or the equation on which it is based.

Different materials will have different temperature coefficients. As a result, the temperature correction equation will vary depending on the material being tested.

Copper – Temperature/Resistance Relationship

Temp. °F	Temp. °C	Resistance μΩ	Percent Change
-40°	-40°	764.2 μΩ	-23.6%
32°	0°	921.5 μΩ	-7.8%
68°	20°	1000.0 μΩ	0.0%
104°	40°	1078.6 μΩ	+7.9%
140°	60°	1157.2 μΩ	+15.7%
176°	80°	1235.8 μΩ	+23.6%
212°	100°	1314.3 μΩ	+31.4%
221°	105°	1334.0 μΩ	+33.4%

$$R_{(end\ of\ test)} / R_{(beginning\ of\ test)} = (234.5 + T_{(end\ of\ test)}) / (234.5 + T_{(beginning\ of\ test)})$$

**Trending**

In addition to comparing measurements made with a low resistance ohmmeter against some preset standard (spot test), the results should be saved and tracked against past and future measurements. Logging of measurements on standard forms with the data registered in a central database will improve the efficiency of the testing operation. Prior test data can be reviewed by the operator, and then on-site conditions can be determined.

Developing a trend of readings helps the operator better predict when a joint, weld, connection, or other component will become unsafe, and make the necessary fix(es). Remember that degradation can be a slow process. Electrical equipment faces mechanical operations or thermal cycles that can fatigue the leads, contacts and bond connections. Additionally, these components may also be exposed to chemical attack from either the atmosphere or man-made situations. Periodic testing and recording of the results provides a database of values that can be used to develop resistance trends.

*Note: When taking periodic measurements, the operator should always connect the probes in the same place on the test sample to ensure similar test conditions.*

Following are several examples of where trending can help the operator make better-informed maintenance decisions:

**Circuit Breakers**

As noted previously, mechanical wear and tear on circuit breaker contacts that reduces the area of the contact surfaces combined with sparking and/or arcing will increase the resistance across the working connections. This condition will produce heat that can reduce the effectiveness of the circuit breaker. Periodic measurements will show the rate of increase of the contact resistance value. When these values are compared to the original manufacturer's specification, a decision can be made to continue or repair. By tracking the trend of the readings, the operator will get an idea of when the circuit breaker should be pulled for service before damage is done.

**Stand-by Battery Back-up Systems**

The interface between the terminals and the straps on battery back-up systems is subject to chemical attack from the acid atmosphere, thermal changes due to the charging and discharge currents and mechanical stress from vibration. Each of these factors can cause the resistance bond to degrade, resulting in the potential for a fire at a critical power discharge (due to the hydrogen gas atmosphere). Battery systems require diligent attention, as replacement batteries are both expensive and not off-the-shelf items. A failure situation can result in a battery system being out of service for a number of weeks. Periodic measurements of the strap resistance will identify those bond connections that have degraded since the last test and corrective action can be planned.

*Note: When connections have higher than normal resistance measurements, the operator should not retighten the bolts, as this will over stress the soft lead connection. Over tightening does not cure the problem. The proper procedure is to disassemble the straps, clean, grease and then reconnect with the bolts tightened to the supplier's torque level. All the connections should be balanced within a narrow tolerance of ±10 to 20%.*

In these and many other systems, time lost to repair defective equipment may be small compared to the cost of having equipment out of service for weeks. Periodic testing can avert many problems. Analyzing data against past results and reasonable standards allows the operator to select the time when corrective work should be done.

The value of a system is in its ability to perform on demand. Operations are predicated on many systems being available at an instant's notice. When elements break, production is lost and time is wasted making emergency repairs. Taking and analyzing periodic low resistance measurements saves companies money by helping identify problems before they result in catastrophic failure.

The practical example shown in Figure 15 shows how trending low resistance measurements made on a periodic basis provides critical information to the operator. When low resistance measurements are made on stranded cables on spot welding robot #23, the operator is gathering data to estimate when fatigue to the current conductor will degrade the quality of the weld nugget. The test data begins with the wire manufacturer's specifications. It has been determined that a resistance increase of up to 10% is acceptable. In this case, measurements are made after a specific number of weld operations. When charting this data, observe the rate of change as the readings approach the end of life for the stranded cable (see Figure 15). The critical factor could have been long-term exposure to a chemical solvent. In other operations the critical factor is time, with testing performed seasonal or on specified number of days.

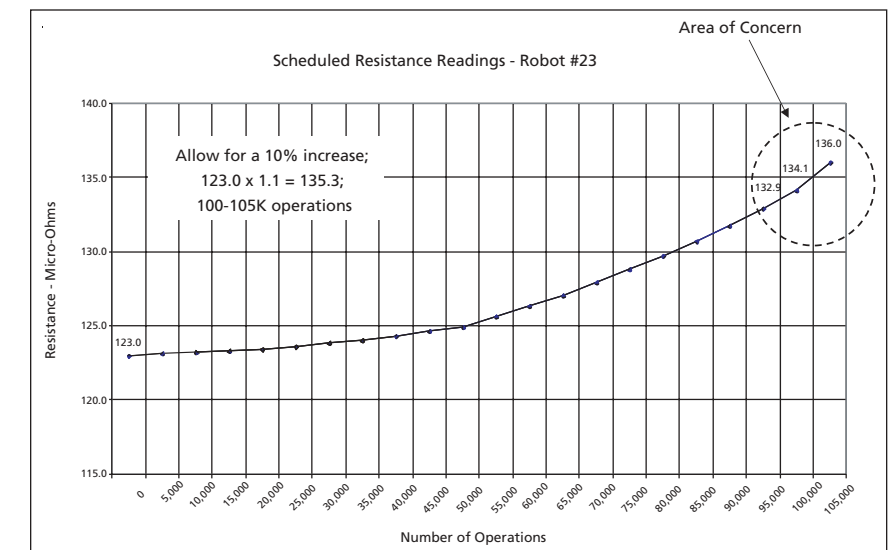

Figure 15: Trending Analysis of Low Resistance Readings

**APPENDICES**

**Potential Sources of Error/Ensuring Quality Results**

The operator can compromise low resistance measurements if the wrong test equipment is selected or the temperature at the test site is not determined and noted on the test data sheet. Prior to testing, surface preparation may be critical. Heavy scale or oxide coatings should be removed to expose a clean surface and ensure good current connections.

**Test Leads/Probes**

An instrument's specification should have a recommended listing of suitable test leads. The operator should always verify that the correct leads are being used as leads may look alike but have different resistances, which may limit the maximum current that the instrument can produce.

Do not use thermocouple extension wire in place of copper leads as the material mismatch will produce erratic data that will change as the site temperature varies with the seasons.

The probe selection is also critical. High current tests require secure connections to the work surface because high resistance at the contacting point can limit the expected level of test current, causing a poor signal-to-noise ratio, with erratic results. Use of unsuitable probes for the particular application can lead to unreliable results.

In all cases tests are performed with current injection and potential measurements made at separate locations on the component. Potential test clips must never be connected to the current connection as the voltage drop at the current interface will be added to the potential measurement and produce an error in the reading. The ideal current connection injects current above the potential measurement position. When these points are close to each other the Kelvin Clip or C-clamp connectors are used, injecting current 180° from the potential connection (see Figure 16).

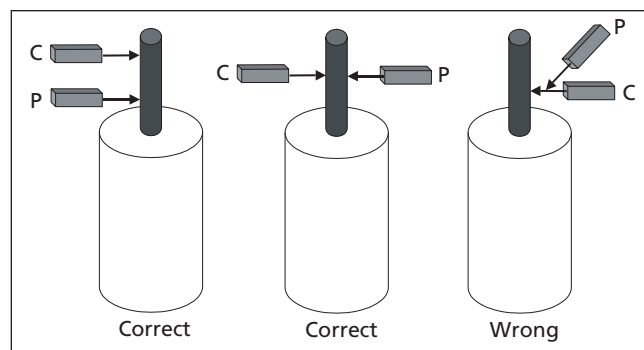

Figure 16: Correct and Incorrect Probe Placements

Probes are available in five basic styles; each is designed to address specific field and/or application situations. Figure 17 shows some of the different styles.

*Fixed Point:* Most economical and lightweight probes.

*Kelvin Clips:* Feature spade lugs on the outboard end and alligator clips with insulated silver or gold plated jaws.

*Linear Spring Points:* These probes are designed with spring points, which recess into the handle to allow for unevenness of the surface. They are designed for clean surfaces as they have no "cutting" action to allow them to bite through surface contamination.

*Helical Spring Points:* Tips rotate and compress into the body of the probe, allowing the probes to break through any grease or surface film, ensuring an accurate measurement. Additionally, these probes will leave a mark on the test surface to identify the points where the test was performed. Care should be taken when using these probes if the surface being contacted is sensitive to pressure points.

*C-Clamps:* Current passes through the C-clamp and screw thread while the potential passes through a four-point anvil insulated from the clamp metal.

The test leads are matched to battery-operated meters to ensure that the nominal level of test current will be delivered to the test specimen.

Finally, probes are designed to make electrical connection with the test sample. They are not intended to be used to clean surfaces, open tins, etc.

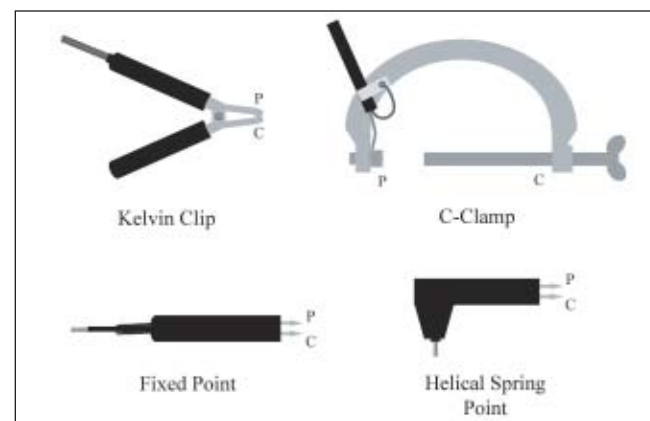

Figure 17: Basic Styles of Probes

**Accuracy Statements**

Quality low resistance ohmmeters will show their accuracy statement as "±X.X% of reading, ±X lsd." Beware of instrument accuracies stated as a percent of range rather than a percent of reading. While these accuracy statements may look alike, the measurements made on an instrument with (% of range) accuracy would provide readings that are less accurate.

The resolution of an instrument reading is typically one-half the least significant digit (lsd) noted in the accuracy statement. The magnitude of the lsd influences the repeatability of the measurement. A large lsd number is due to the low sensitivity of the instrument, adding an additional error to the measurement.

Check the temperature coefficient of the selected instrument. The temperature coefficient (% of reading per degree) is multiplied by the site temperature difference from the instrument's calibrated temperature and will influence the accuracy of the field measurements. An instrument that includes an accuracy notation of +0.2%/°C should not be used in the field, as its best utilization would be in a laboratory with a constant ambient environment.

The operator must be aware of all these characteristics when selecting the test instrument.

**Interference**

A strong electrical field, flux linkage from a high current circuit or voltage induced from a high voltage conductor can cause interference at the test site. In addition ground currents can induce noise on a conductor. Interference can reduce sensitivity and produce unstable readings. An instrument with low noise rejection, or hum attenuation may be stable when tested on the bench but be erratic in selective field conditions. Modern electronics can detect the level of noise and some instruments use this to indicate when excessive noise is present to make a valid measurement.

**Delivery of Stated Test Current Under Load**

Battery operated, digital low resistance ohmmeters have different test currents dependent on the selected range. The lowest resistance range has the highest current level and as the range increases the current will decrease. (As the range increases by a factor of ten the test current will decrease by a factor of ten.) This feature allows for an effective balance between weight and functionality.

The output current delivered by the instrument is not critical, as the instrument will be measuring the actual test current at the time of the test. However, the instrument must be able to deliver sufficient current to produce a clear signal in the presence of typical noise. A typical instrument can have a 10% to 20% tolerance on the maximum current rating. But, to make a good potential measurement, the current must be stable. The critical factor for the measurement is the voltage measurement via the potential leads (Ohms Law; R = V/I).

The one testing area where the test current is critical is on a transformer due to the magnetic characteristics of the winding. Sufficient current is needed to saturate the winding, and then a lower constant current is used to perform the measurement.

**Taking the Measurement at a Stable Plateau**

A de-energized test specimen provides a stable platform on which to make the measurement. Live circuits can produce an unstable test platform. An example of the latter is the testing of battery straps on a UPS system. The charging and/or discharging currents may induce noise across the battery straps being measured, and at the same time cause the resistance values to increase (due to heating of the strap and its connections). When collecting data, the operator must define the test conditions. As noted previously, temperature can have a significant influence on any measurements made. The operator should note the temperature and document any electrical equipment that is in operation in the test area.

**Material Resistivity**

Conductors of the same dimensions have different resistances if they are made of different materials due to varying number of free electrons in varying substances. We account for these differences with the term resistivity, which is the resistance of a sample of the material having dimensions with specified unit values. While scientists tend to look at cubes of material as the measurement standard (one centimeter cube or one inch cube), conductors tend to be circular, making a circular standard important for practical use. The resistivity of a material is defined in ohm-circular mils per foot; that is, the resistance (in ohms) of a piece of material one foot long and one circular mil cross section. It is defined at a temperature of 20° C/68° F.

The following table shows the resistivities for a number of conducting materials<sup>iv</sup>:

**Resistivities of Conductors**

Substance	Micro-Ohms		Ohm-CM per Foot
	CM Cube	In. Cube	
Aluminum	2.83	1.11	17.0
Carbon (Graphite)	700	275	4210
Constantan (Cu 60%, Ni 40%)	49	19.3	295
Copper (annealed)	1.72	0.68	10.4
Iron (99.98% pure)	10	3.94	60.2
Lead	22	8.66	132
Manganin (Cu 84%, Ni 4%, Mn 12%)	44	17.3	264
Mercury	95.78	37.7	576
Platinum	9.9	3.9	59.5
Silver	1.65	0.65	9.9
Tungsten	5.5	2.17	33.1
Zinc	6.1	2.4	36.7

In most field applications the operator will determine the suitability of a field measurement against a pre-selected specification. In most cases, these specifications have been generated from the following formula (at 20° C/68° F):

$$R = \rho L/A$$

Where:

$\rho$  = resistivity of the material in ohm-CM per foot.

L = distance between two points on the material, in feet.

A = cross section area measured in circular mils.

**Effects of Temperature on Measured Resistance Values**

Resistance measurements are dependent on temperature. If the original data was read at one temperature but later tests are conducted at other temperatures, this temperature data is required to determine the suitability of the measurements. All materials do not react to temperature to the same degree. Aluminum, steel, copper and graphite have specific temperature coefficients that will affect the degree of changes that may take place with temperature at the site of the measurement.

<sup>iv</sup> Electrical Metermen's Handbook; Third Edition; 1965; page 479

<sup>v</sup> Electrical Metermen's Handbook; Third Edition; 1965; page 480

Low resistance measurements rely on the operator conducting the tests within the operating temperature range of the instrument (the operator must be aware of field conditions). When the operator sees out-of-tolerance measurements, one of the first steps is to verify the instrument's reading with a suitable calibration shunt.

As mentioned previously, resistance measurements are dependent on temperature. The resistance of all pure metals increases with rising temperature. The proportional change in resistance for a specific material with a unit change in temperature is called the temperature coefficient of resistance for that material. Temperature coefficients are expressed as the relative increase in resistance for a one-degree increase in temperature. While most materials have positive temperature coefficients (resistance increases as temperature rises), carbon graphite materials have negative temperature coefficients (resistance decreases as temperature rises).

The following table shows the temperature coefficients of resistance for selected materials<sup>v</sup>.

**Temperature Coefficients of Resistance**

Material	Per °C	Per °F
Aluminum	0.0038	0.0021
Carbon (0-1850 °C)	-0.00025	-0.00014
Constantan (0-100 °C)	negligible	negligible
Copper (@ 20 °C)	0.00393	0.00218
Iron	0.0050	0.0028
Lead	0.0043	0.0024
Manganin (0-100 °C)	negligible	negligible
Mercury	0.00090	0.00050
Platinum	0.0038	0.0021
Silver	0.0040	0.0021
Tungsten	0.0045	0.0025
Zinc	0.0037	0.0021

Figure 18 shows the temperature-resistance curves for some of these materials (based on a baseline reading of 1000 micro-ohms at 20° C).

When making a measurement on a specific material, the operator can calculate the change in resistance due to a change in temperature by multiplying the resistance at the reference temperature by the temperature coefficient of resistance and by the change in temperature.

$$R_2 - R_1 = (R_1)(a)(T_2 - T_1)$$

Where:

$R_1$  = resistance of the conductor at the reference temperature

$R_2$  = resistance of the conductor when the measurement is made

$T_1$  = reference temperature

$T_2$  = temperature at which the measurement is made

a = temperature coefficient of resistance for the material being tested

The operator should also be aware of operating and storage temperature specifications of the instrument he/she is using to ensure that it is suitable for the environment in which it will be used.

**Effects of Humidity**

The relative humidity of the test specimen should not affect the resistance reading unless the material is hygroscopic, in which case more moisture will be absorbed into the sample at higher humidities. This will change the measurement conditions and will affect the achieved result. However, most conductors are non-hygroscopic. Therefore, since instruments are typically designed with an operating range of from 0 to 95% RH, providing that moisture is not actually condensing on the instrument then a correct reading will be obtained.

**Background Noise Conditions, Current and Voltage**

Resistance measurements can be degraded by static voltages and ripple currents (electrical noise) impressed on the test specimen. The operator should be aware of the level of noise rejection in the instrument being used. Changing to a different model may help the operator make a measurement at a difficult test site.

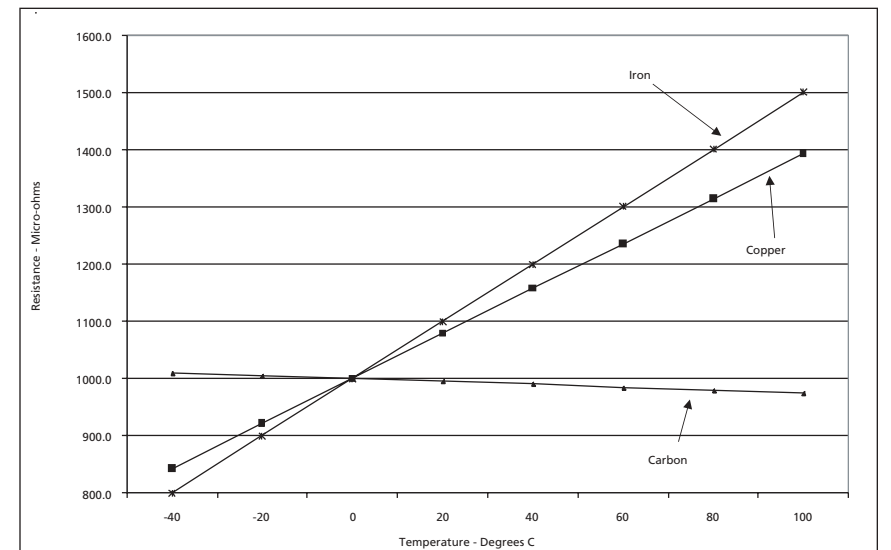

Figure 18: Temperature-Resistance Curves for Iron, Copper and Carbon

The magnitude of the test current used by the instrument will affect the noise rejection capability of that instrument. A 10 Amp test current will provide much better noise rejection than a 0.1 Amp test current. Beware of excessive test currents which can change or damage the test sample due to heating ( $W = I^2R$ ). If 100 Amp is used in place of 10 Amp, the sample will experience 100 times the heat of the lower test current.

The open circuit voltage on most low resistance ohmmeters is low. When making measurements on transformer windings, additional power is required to saturate the winding and allow the meter to stabilize more rapidly. Instruments designed for this type of application have a higher open circuit voltage (in the 30 Vdc range) to deliver the energy needed to saturate the windings. Then a constant current mode of operation is used to perform the resistance measurement.

**Use and Misuse of Low Resistance Ohmmeters**

The effective operation of a low resistance ohmmeter relies on the operator using the correct test leads. Battery operated instruments are designed for a specific lead resistance, based on the operational life of the test sequence. The specified leads allow for a reasonable current drain from the power supply for the testing cycle. If leads with a higher resistance are used, the current used for the testing may be lower than the meter requires, potentially causing a signal-to-noise problem that may reduce the accuracy and/or repeatability of the measurement.

If leads with lower than the specified resistance values are used, the test cycle for the instrument will be shorter than anticipated. This situation may be suitable if the meter is to be used in a test program with high background electrical noise. The use of special leads with shielding may also be a solution for these high noise situations.

A common error in the field is to use a low resistance ohmmeter to sample the resistance of a ground bed. This application is incorrect, as the ground bed test method requires an instrument that toggles the test signal at a known frequency and current level. A low resistance ohmmeter used in this application will provide an erroneous reading as the ground current will have an undue influence on the measurement. A proper ground tester performs in essentially the same way as a low resistance ohmmeter, that is, by injecting a current into the test sample and measuring the voltage drop across it. However, the earth typically carries numerous currents originating from other sources, such as the utility. These will interfere with the dc measurement being performed by a low resistance ohmmeter. The genuine ground tester, however, operates with a definitive alternating square wave of a frequency distinct from utility harmonics. In this manner, it is able to perform a discrete measurement, free of noise influence.

**Brief History of Low Resistance Ohmmeters**

The original DUCTER™ low resistance ohmmeter<sup>vi</sup> was developed by Evershed & Vignoles (one of the companies that evolved into Megger and the developer of the first insulation resistance tester) in 1908 and employed the cross-coils meter movement that was already used in the insulation resistance tester. This initial design evolved into field units in the 1920s that required a leveling procedure at the time of the test due to the sensitivity of the coil (to being level). These early models did not travel well and were sensitive to shock and vibration.

For fifty years, field portable low resistance ohmmeters were analog units. In 1976, in response to numerous customer requests, the James G. Biddle Company (another one of the companies that ultimately became Megger) developed and introduced a digital low resistance ohmmeter. This unit was known by its trade name, the DLRO® (a registered trademark of Megger). Ultimately, the James G. Biddle Company released 10 amp and 100 amp versions of the DLRO, including a single box design for some versions that simplified the testing process, and an extended range model.

This style of instrument served the industry well for a number of years, and the various versions continue to help end users solve problems. However, electronics and battery technology advanced to the point where a considerable number of improvements could be made to the 1970s designs. Newly designed low resistance ohmmeters by Megger include data storage and downloading capability, additional test modes, reduced weight, extended battery life, etc.

**Calibration**

Calibration of low resistance ohmmeters can be checked in the field by the use of a shunt. Calibration is performed with individual current and potential 12-gauge copper leads to ensure correct current distribution through the shunt and an accurate potential measurement. Be aware that “test probes” do not provide accurate positioning of the leads to verify the instrument calibration. They can, however, be used to determine the relative calibration of the instrument.

The following table shows commercially available shunts:

Resistance ±0.25% Value	Current Rating
10.000 ohm	1.0 mA
1.0000 ohm	10 mA
0.1000 ohm	100 mA
0.0100 ohm	1 A
0.0010 ohm	10 A
0.0001 ohm	100 A

These calibration shunts when used with a Certificate of Calibration, traceable to National Standards, help the field service engineer demonstrate to a customer the accuracy of the tests being conducted.

**Ingress Protection**

Somewhere in the fine print (specifications) of most test instrument product bulletins is an IP rating, a number that gives the operator vital information. In fact, the IP rating lets the operator know whether a piece of test equipment is suitable for his/her application and test environment.

“IP” stands for “ingress protection.” That is the degree to which the instrument can withstand invasion by foreign matter. The IP rating system has been established by the IEC (*International Electrotechnical Commission*), in their Standard 529, and is used as a guide to help the operator protect the life of the instrument. It also can help the operator make a more informed purchase decision by ensuring that the piece of test equipment is designed to work in the environment(s) that the user faces.

The IP rating is comprised of two digits, each signifying a separate characteristic. The designation indicates how well the item is sealed against invasion by foreign matter, both moisture and dust (the higher the number(s), the better the degree of protection). What would a typical rating of IP54 tell a buyer about the application capabilities of a model? If you want to sound thoroughly knowledgeable, that’s IP five-four, not fifty-four. Each digit relates to a separate rating, not to each other.

The first digit refers to particulate ingress, reflecting the degree to which solid objects can penetrate the enclosure. A level of “5” indicates “dust protected” as well as protected from invasion with a wire down to 1.0 mm. There is only one higher category: “dust tight.”

The second digit refers to moisture. A rating of “4” means resistance to “splashing water, any direction.” The higher ratings of 5 through 8 indicate “jetting water” and “temporary” or “continuous” immersion.

As an example, suppose an instrument under consideration was rated only to IP43. What would that tell the operator about its usability? Could it be thoroughly utilized in a quarry or cement plant? Hardly! The particulate rating 4 indicates “objects equal or greater than 1 mm.” That’s a boulder in comparison to particles typically produced by industrial processes. Flying dust could put the instrument out of commission.

Suppose the instrument is rated at IP42. A moisture rating of 2 indicates dripping water. Therefore, it would not be resistant to flying spray. Acquiring an instrument for an environment that exceeds its IP capabilities likely means that the operator will need another very soon. What about a rating of IP40? A moisture rating of 0 means that the instrument is not protected against **any** liquid ingress.

The following charts provide a guide to various IP ratings and what they mean to the operator.

**Protection against Access to Hazardous Parts (First Digit)**

Number	Description
0	Non-protected
1	Protected against access with back of hand (50 mm)
2	Protected against access with jointed finger (12 x 80 mm)
3	Protected against access with a tool (2.5 mm)
4,5,6	Protected against access with a wire (1.0 mm)

**Protection against Ingress of Solid Foreign Objects (First Digit)**

Number	Description
0	Non-protected
1	Objects equal or greater than 50 mm
2	Objects equal or greater than 12.5 mm
3	Objects equal or greater than 2.5 mm
4	Objects equal or greater than 1 mm
5	Dust protected
6	Dust tight

**Protection against Ingress of Liquids (Second Digit)**

Number	Description
0	Non-protected
1	Water dripping vertically
2	Water dripping, enclosure tilted up to 15°
3	Spraying water, up to 60° angle from vertical
4	Splashing water, any direction
5	Jetting water, any direction
6	Powerful jetting water, any direction
7	Temporary immersion in water
8	Continuous immersion in water

vi Basic Electrical Measurements; Melvin B. Stout; 1950; page 61

**Various Test Modes**

Digital low resistance ohmmeters designed in the 1970s and 1980s tended to offer two modes of operation, each designed for specific applications. Recent microprocessor technology has allowed newer instruments to include additional modes, further extending the capabilities of these models. Following is a brief review of the types of test modes available on different vintage instruments:

**Models Designed in the 1970s and 1980s**

*Continuous Mode:* This switch position allows the test current to flow and a measurement taken when the current and potential probes contact the test specimen. This mode of operation is usually implemented when the helical spring-point lead sets are used and is the normal method when conducting field tests. Battery life is extended, as the test current flows only when the tests are performed.

*Momentary Mode:* This switch position requires both sets of test leads to be connected to the specimen. The measurement is performed when the switch is toggled to the momentary position. This mode of operation is used when separate current and potential leads are connected to the specimen.

**Recently Designed 10 Amp Models**

*Normal Mode:* Test mode where the operator connects all four test leads and presses the test button on the instrument to initiate a test. The instrument checks the continuity of the test connections and then applies forward and reverse current. The reading is displayed for a short period (10 seconds).

*Auto Mode:* Test mode that allows forward and reverse current measurements to be made (the average value is displayed) simply by making contact with all four probes. Each time the probes are removed and reconnected to the load, another test is performed. This mode, which is similar to the Continuous Mode found on older instruments, is an excellent time-saving method to use when testing battery straps with handspikes. It has the added advantage, when testing with handspikes, that the contact detection sensing ensures good contact before applying heavy currents. This avoids arcing when contact is made, which erodes the probe tips as well as potentially damaging the surface of the item under test.

*Continuous Mode:* Test mode that allows repeated measurements to be made on the same test sample. Once the test leads are connected and the test button pushed, a measurement is made every set number of seconds until the circuit is broken.

*Unidirectional Mode:* This mode applies current in one direction only. While this type of measurement does not negate standing emfs, it does speed up the measuring process. In many test conditions, such as testing battery straps, it is not necessary to perform a reversed current test on the sample. This mode is also used when testing objects with inductive properties such as motors and transformers.

**Recently Designed 100+ Amp Models**

*Normal Mode:* Test mode where the operator connects all four test leads and presses the test button on the instrument to initiate a test. The instrument checks the continuity of the test connections and then applies the test current.

*Continuous Mode:* This mode is used to monitor test conditions for a period of time. After the test leads are connected and the test button pressed, tests will be recorded every set number of seconds until the test button is pressed or contact is broken with any of the test probes.

*Auto Mode:* With this mode, because of the heavy test currents used, the operator connects the current leads, selects the desired test current and presses the test button. As soon as the potential leads are connected, a test will begin. To make another test, the operator breaks contact with the voltage probes and then remakes contact. This is an excellent mode for measuring individual joints in a bus bar.

**Nominal vs. Absolute Test Current Levels**

Battery operated digital low resistance ohmmeters have different test currents, which are a function of the selected range. The lowest range has the highest current level and as the range increases the current decreases. As the range increases by a factor of 10, the test current will decrease by a factor of 10. This action allows for a balance of weight and function; if the current were to increase as the range increases, this field instrument would lose much of its portability, and its usefulness for field-testing would decrease significantly. In power plants, substation and distribution sites, the test equipment is exposed to interference from high currents generated in the area. The operator will have to determine the test current level to provide the most accurate and repeatable measurements.

Industry-standard test currents were originally developed according to available technology in metering. With early technology, enormous currents were needed in order to develop a measurable voltage across a test sample with negligible resistance. By Ohm's Law, a typical meter of 1 millivolt full scale would require 100 amps in order to measure as little as a micro-ohm. The micro-ohm being the preferred unit of measurement for low-resistance testing, this made 100 amp testers the standard design for early instrumentation.

Unfortunately, this design made for testers that were large, difficult to move, and of limited practicality in the field. The development of cross-coil movements, with the balancing of voltage and current in two separate coils driving the pointer, produced a dramatic increase in sensitivity, and brought workable test currents down to the familiar 10-Amp level. Of course, microprocessors have further extended the sensitivity of modern instruments. But this process is limited by the need for adequate noise suppression. Low resistance ohmmeters measure at levels several powers of ten lower than common multimeters. Noise becomes large by comparison, and makes noise suppression critical to the adequate function of the instrument. The tester, therefore, must maintain an adequate signal-to-noise ratio.

Testers with large current outputs are still widely used, however, for testing specific types of equipment. The limiting factor on the high end is principally the generation of heat. Testing at too high a current can cause a heating effect on the measurements, be injurious to the test item, and even cause welding of contacts. Certain types of equipment such as high voltage ac circuit breakers (see IEC62271-100) have sufficiently large conductors and areas of contact to carry currents of several hundred amps without experiencing these harmful effects. The demand for test current is critical when testing coils, transformers or other magnetic components due to the inductive characteristics of these types of components. Industry standards, then, may call for some specified high current. Such selection is typically a compromise between various factors as discussed above, with a view toward practicality, rather than scientifically justified demands. Sophisticated testers will automatically balance current against the load, for maximum precision and minimum heat effect, so that it is not necessary to impose specific, pre-selected values on the test procedure. Some suppliers specify 200+ amps for SF6 breaker contacts in order to overcome oxidation on the contact surfaces.

*Note: The Kelvin Bridge instrument, which has been used to make measurements in the sub-micro-ohm region, uses approximately 5 A of test current.*

**Autoranging**

Autoranging capability in an instrument allows the operator full use of the test probes. An autoranging instrument automatically selects the range with the fullest use of the display, providing the most sensitive reading for the measurement and optimizing the resolution of the reading. When taking a series of readings, the operator will be able to maximize the use of his/her time.

**Transformer Testing**

Regular testing of transformers can help identify problems that reduce system performance and can lead to unexpected outages. The dc resistance of a transformer winding can indicate the internal temperature of the winding when the resistance at ambient is compared to the hot resistance. The ideal test method is to make resistance readings at one-minute intervals as the hot winding is cooling. When this data is charted, the resistance at time zero can be estimated (see Figure 19).

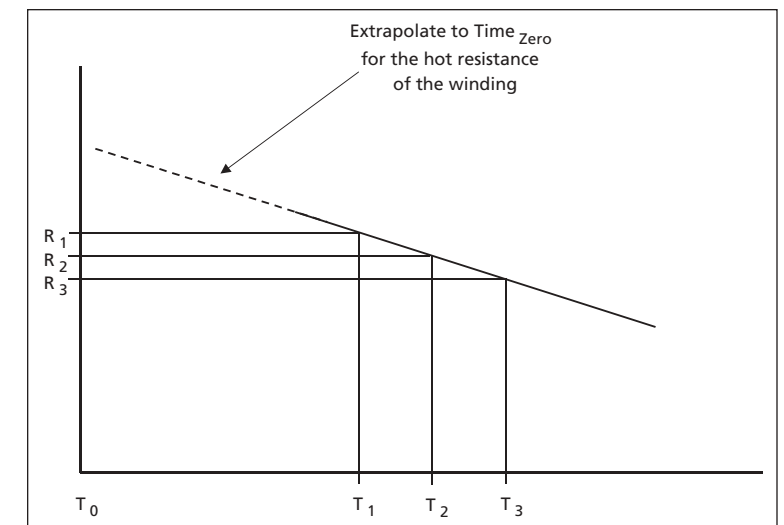

Figure 19: Resistance Graph of Cooling Transformer Windings - Heat Run

The typical test will indicate excessive overheating in the coils due to fatigue or corrosion of the internal coil and/or the internal connections. Low resistance testing on transformers addresses small, medium, large single, large poly-phase and auto-transformer windings. Tests are performed on:

- Dual windings with the test current connected through the windings in opposed polarities.
- Wye to wye windings with and without a neutral connection; the leg of the other winding is connected to the potential lead to measure the voltage at the internal connection.
- Wye to delta windings; a jumper is used to connect the current from the wye winding to the delta winding (this test mode reduces the test time).
- Delta to delta windings; the test time can be improved by connecting the current jumper to the primary and secondary of the same phase in opposed polarities.

Taps are used to improve voltage regulation and are adjusted daily. Excessive wear and loosening due to vibration can be identified with low resistance measurements. Consecutive tests can be performed on secondary tap changers (shorting style of taps). Large transformers have many tap positions and test time will be reduced, as the test current does not have to be shut off between tests. Tests on primary taps (open taps) must be performed as individual tests with the test current shut off between tests.

The low resistance ohmmeter must have sufficient current capacity to saturate the windings. The testing time will depend on the available test current. Large transformers require special attention prior to performing the tests. The insulation between the windings will store energy, similar to the dielectric in a cable, and must be discharged before a test can be performed.

When testing three-phase transformers, interaction will occur between the primary and secondary windings. This situation will be most evident when testing transformers with wye and delta windings, and can be minimized by connecting the test current to flow through both primary and secondary windings. The net effect is to reduce the mutual coupling between the windings and minimize the flow of circulating current in the delta winding.

Test current should be limited to the magnetizing current, which is about 1% of the full load current. The lower test currents reduce stress in the magnetic core of the winding. Large test currents produce large forces on the core and may cause damage.

**Bar to Bar Testing**

Helical spring point probes are used to measure the value of the bar to bar resistances of the rotor in a dc motor (see previous Figure 2). This test is typically performed at the 10 Amp current level with the typical coil resistance measurements in the 6000 micro-ohm range. These tests identify broken/loose welds or solder connections between the coils and commutator bars. The resistance measurements should remain consistent. Readings may be higher on a heated motor, due to the temperature of the coils. As the coils cool, the resistance values may drop to some prior reference value recorded at ambient temperature.

Figure 20 shows a lap winding, a style where the windings are connected to bars laying next to each other. To make a test, the current probe should be placed at the end of the commutator bar and the potential probe should be placed at the connection to the winding (the riser on the commutator bar). The operator measures the resistance of the windings between each set of bars being tested (1-2, 2-3, 3-4, etc.). In this example, there is a possible weak solder joint between bars 4 and 5, and a break in the coil between bars 12 and 13 (the instrument will indicate this as an open).

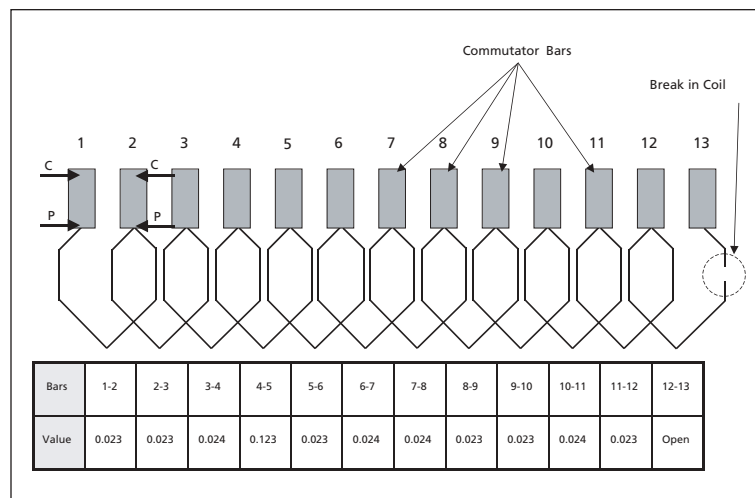

Figure 20: Testing a Lap Winding

In Figure 21 (lap winding, 24 coils), all the coils are connected in series. The resistance of each coil will be measured with the resistance of all of the other coils connected in parallel. The primary question for the operator is what constitutes an acceptable reading for a specific coil ( $R_m$ ) since the remaining 23 coils in parallel will lower the resistance of the coil being tested. For this example, we will assume that the resistance of the coil before insertion into the motor ( $R_c$ ) was 1.00 ohm. The expected resistance can be calculated by the equation:  $Expected R_m = (R_c)(\# \text{ of coils being tested})/(\# \text{ of coils in parallel})/(\# \text{ of coils being tested} + \# \text{ of coils in parallel})$ . In this example:

$$Expected R_m = (1.00 \text{ ohm})(1)(23)/(1 + 23)$$

$$Expected R_m = .958 \text{ ohm}$$

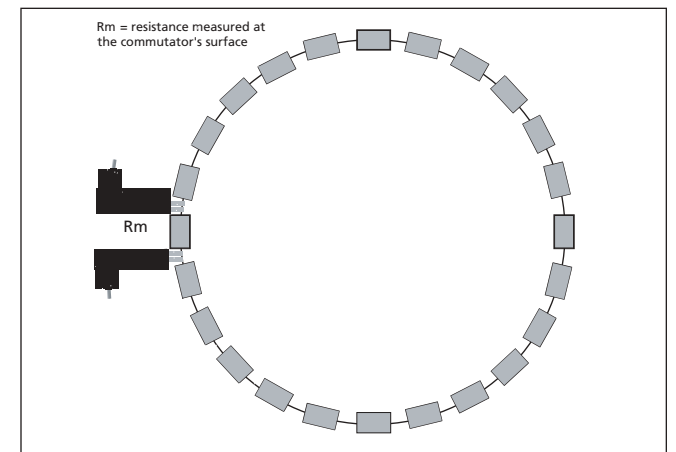

Figure 21: Commutator with 24 Coils in Series

Figure 22 shows a wave winding, another manufacturing technique for putting high resistance coils in a motor. In this example, the coil runs from commutator bar 1 to 6 to 11 to 16 and then loops back around the armature to commutator bar 2 (connected in series). When the operator measures between bars 1 and 2, he/she is checking the resistance of the wave wound coil (the complete loop). In this example, there is a break in the coil between bars 12 and 17. This problem will appear when measuring bars 2 and 3, since they are the beginning and end bars of the loop.

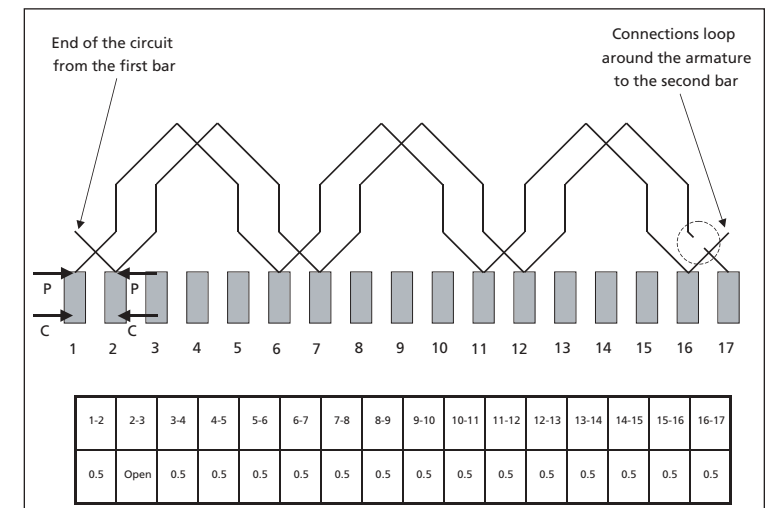

Figure 22: Testing a Wave Winding

Figure 23 shows wave winding commutator connections to the internal coils and test probe connections to individual commutator bars. This is a simplified layout, as the heavy ring shows the series connections for all the coils in the armature. A dc motor will have a different number of coils depending on the horse power and the voltage rating. In this example (testing from bar #1 to bar #2), two coils are in series and nineteen are in parallel. If one coil is open in the ring, the measurement from bar #1 to bar #2 will be the series value of the two coils. If the test probes are across the open coil, the total resistance of the other nineteen coils will be displayed.

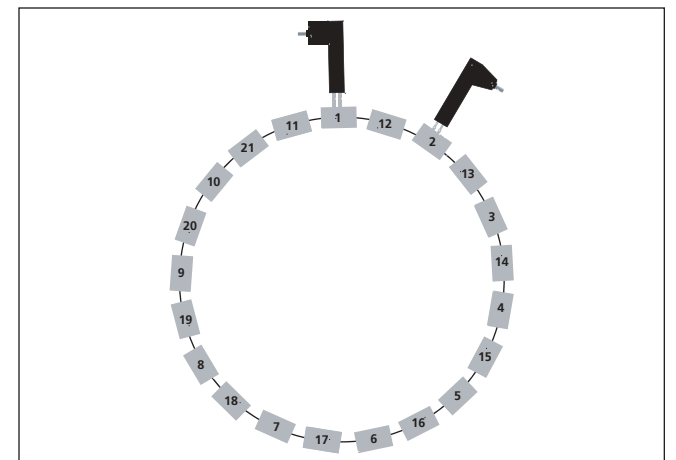

Figure 23 Coil Arrangement in a Wave Winding

**Battery Strap Testing**

When testing battery straps, the operator should have baseline values or targets to compare against the actual results. Following are several examples of how these target levels are determined.

In the first example (see Figure 24), the operator is measuring the resistance ( $R_0$ ) across a single battery strap (both sides of the terminal). The straps on each side of the terminal have a resistance of 20 micro-ohm and the connections to the terminals each have a resistance of 5 micro-ohm. Under these conditions, the target resistance that the operator wants to see is 15 micro-ohm. A significant variance from this resistance in the actual reading would indicate loose connection.

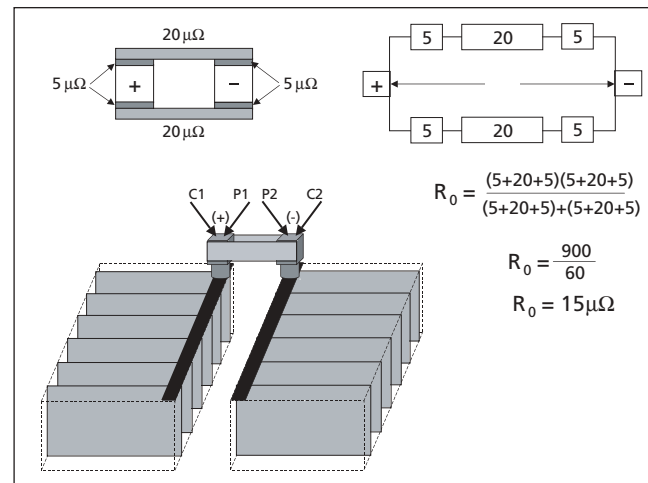

Figure 24: Single Strap Resistance Target

The second example (see Figure 25) shows terminals connected in parallel by carrier strips with a resistance of 100 micro-ohms. In this case, the target resistance that the operator wants to see is 14 micro-ohms.

If there were an open strap between terminal "a" and terminal "b," the resistance reading would be significantly higher than the target, as follows:

$$R_{a-b} = R_{a-c} + R_{c-d} + R_{b-d}$$

$$R_{a-b} = 100 + 15 + 100$$

$$R_{a-b} = 215 \mu\Omega$$

Additional tests can be performed between the same polarity terminals on a cell. Such a test will help determine the quality of the terminal-to-bar welds and major problems with the internal bar to which the plates are welded, as all are series connected. In this example, the measured resistance between like terminals on the same cell should be in the 100 micro-ohm range.

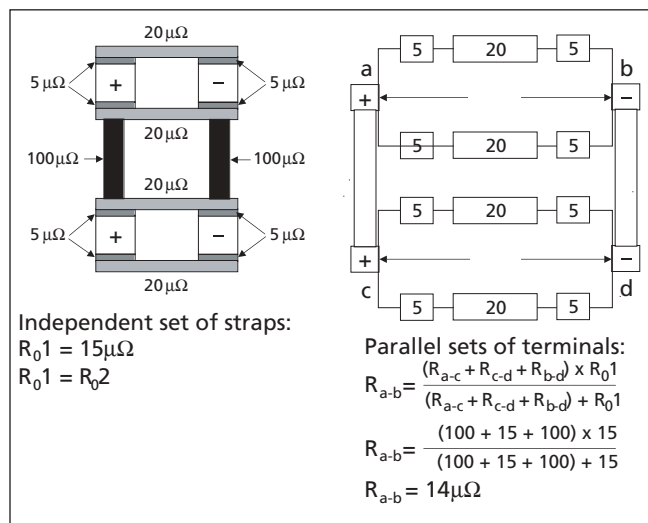

Figure 25: Parallel Strap Resistance Target

**Wheatstone and Kelvin Bridges**

**Wheatstone Bridge**

A pioneering method for measuring resistance was devised in 1833 by S. H. Christie and made public by Sir Charles Wheatstone. The simplest arrangement is a square pattern of four resistors with a galvanometer connected across one diagonal and a battery across the other (see Figure 26). Two of the resistors are of known appropriate values and comprise the ratio arm (A + B). A third has a known value which can be varied in small increments over a wide range, and is thus designated the rheostat arm (R). The fourth is the resistance being measured, the unknown arm (X).

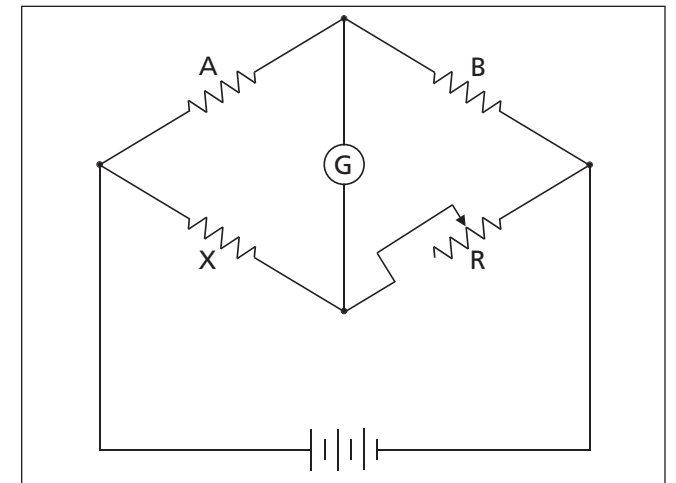

Figure 26: Wheatstone Bridge circuit<sup>vii</sup>

The bridge is considered balanced when the rheostat arm has been adjusted (tweaked) so that current is divided in such a way that there is no voltage drop across the galvanometer and it ceases to deflect (is nulled). The resistance being measured can then be calculated from a knowledge of the values of the ratio resistors and the adjusted value of the rheostat arm. The basic formula is:

$$X = B/A \times R$$

Where:

B and A are the ratio resistors

R is the rheostat

The Wheatstone Bridge can be constructed to a variety of ranges and is generally used for all but the highest and lowest measurements. It is suited to a range of about 1 to 100,000 ohms.

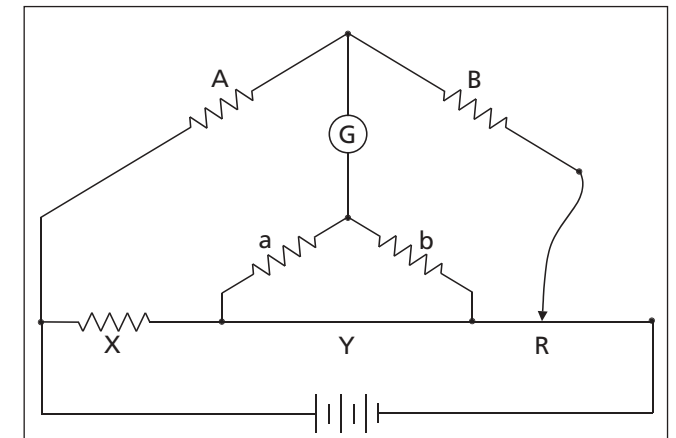

Figure 27: Kelvin Bridge Circuit<sup>viii</sup>

**Kelvin Bridge**

The Kelvin Bridge (also known as the Thomson Bridge) is used for precision measurements below the typical range of the Wheatstone Bridge. Sir William Thomson (Lord Kelvin) devised the concept circa 1854. The classic arrangement has six resistors in a rectangle, bisected by a galvanometer (see Figure 27). A comparatively large current is passed through the unknown resistance and a known resistance of a low value. The galvanometer compares the voltage drops across these two resistances with the double-ratio circuit comprised of the other four resistors.

<sup>vii</sup> Electrical Meterman's Handbook; Third Edition; 1965; page 479

<sup>viii</sup> Electrical Meterman's Handbook; Third Edition; 1965; page 480

For very low measurements, the Kelvin Bridge has the advantage of nullifying extraneous resistances from leads and contacts by employing the system of double-ratio arms. The resistances of the connecting leads are in series with the high-resistance ratio arms and not with the reference or tested resistors. The two pairs of ratio resistors (A/B, a/b) are paralleled with each other and connected across with the galvanometer. One pair (a/b) is in series with the unknown (X) and the reference standard (R). The latter is an adjustable low-resistance, usually a manganin bar with a sliding contact. When potential is balanced across the two parallel circuits, the unknown is equivalent to the parallel ratio multiplied by the adjusted reference value.

$$X = A/B \times R$$

A connecting link (Y), sometimes called the yoke, shunts the ratio pair (a/b) that are otherwise in series with the unknown and standard, but has minimal effect on the accuracy of the measurement so long as the two pairs of parallel ratio resistors are kept exactly equal (A to a, B to b). Lead and contact resistances are included in the value of the ratio pairs, and any effects can be nullified by keeping the resistance of the yoke extremely low. Keeping the yoke resistance low also accommodates the large test currents often used in Kelvin Bridges without causing unwanted heating effects.

## Safety

Safety is the responsibility of the field test engineer or technician, whoever will be in contact with the sample being tested. The majority of field tests are performed on de-energized circuits. When testing magnetic components, a state of winding saturation may occur. The operator should connect a short circuit across the winding to neutralize the energy stored in the winding and then make a voltage test to verify the neutral state of the sample. Some instruments have indication lamps on the test probes to alert the operator to a live voltage condition.

Battery strap testing represents a special condition, as the batteries must remain connected. The operator is required to use insulated gloves, facemask and a body apron for protection when performing these tests. This is one of the few times when electrical resistance tests are performed in the field on energized systems. Special probes, rated for 600 V operation, are available with the newer instruments to perform these tests.

Using instruments with the capacity to store measured values improves the safety as the operator does not have to write down the readings between each test.

## MEGGER PRODUCTS OVERVIEW

Megger offers solutions to ensure electrical system performance with its comprehensive line of Low Resistance Ohmmeters and Micro-ohmmeters

An overview of the various products available is described below. For more information on these and many other Megger products, please contact us at (800) 723-2861 or (214) 333-3201. Or visit our web site [www.megger.com](http://www.megger.com) for the most up-to-date news, product and service information...24 hours a day.

### DLRO-10 Digital Low Resistance Ohmmeter

The most advanced technology provides a 10 Amp tester with highest accuracy (0.1 mΩ), plus modern convenience features to improve and expand testing ease, convenience and capability. Four separate test modes enable the operator to meet specific challenges with maximum efficiency.

In addition to push-button operation in the normal mode, an auto mode initiates a new test automatically every time contact is broken and remade. A continuous mode monitors changes in resistance and displays a new measurement every three seconds. A high-power mode increases power to overcome large inductive loads and provide rapid measurement.

The measurement circuits are designed with extra battery-saving features, so that current flows only when an actual measurement is being made. Reversal of polarity and averaging to cancel standing emfs are performed automatically.

The tester is lightweight and highly portable, affording effortless maneuverability around the test environment. Warning indicators alert the operator to common problems like live voltage or insufficient contact, and the tester comes supplied with a set of duplex handspike leads.



### DLRO-10X Digital Low Resistance Ohmmeter

The DLRO-10X has all the features, benefits and capabilities of the DLRO10 plus more! The DLRO-10X adds data storage and downloading capability, via an RS232 port, to laptop or printer. Up to 700 tests may be stored, with real-time download facilitating even greater storage.

Data management further increases the already prolific benefits available in the DLRO-10. An alpha-numeric keypad affords entry of test notes of up to 200 characters. High/low limits may be set for pass/fail testing, with results included on test reports. Control features include manual current selection, and an additional unidirectional test mode for greater speed where standing emfs are not an issue.





## DLRO600 Digital Micro-Ohmmeter

All the features of the DLRO-10 and 10X, plus additional current up to 600 A to accommodate the preferred standards for the testing of circuit breaker contacts. Yet ease of portability has been retained, with the tester weighing in at only 33 pounds!

Measurement range from 0.1 mΩ to 1 Ω facilitates all standard high current requirements. Memory stores up to 300 results while an RS232 enables downloading to printer or laptop. The added data manipulation capabilities enable current limitation at standard values up to 600 A, thereby eliminating the need for multiple testers in order to conform to a variety of standards.



## Digital Micro-Ohmmeters

For testing to standards that require a more robust current, model **247100** combines the basic features and specifications of the 10 A models with an added power supply (**247120**) that increases test current to 100 A. The power supply attaches by an interconnecting cable to a dual-pak unit that can be used separately as a standard 10 A tester, with added range down to 0.1 mΩ.

If compact design is preferred for the separable 10 A unit, model **247101** provides the 100 A supply with a single-pak module.



Cat. No. 247101

## Series 247000 Digital Low Resistance Ohmmeters

This traditional line from Megger has been the hallmark of quality and reliability since the emergence of the DLRO, and remains as popular today as ever. Decades of proven field use have made them the defining standard in ruggedness and portability.

Three 10 A models in the series offer highest accuracy combined with user-friendly ease of operation.

**Cat. No. 247000** features the tried and popular dual-pak design, where the charger is a separate piece that can be left behind while the measuring module affords the maximum in portability. Where self-containment is a premium, **Cat. No. 247001** combines the measurement module and charger in a single-pak unit without loss of convenient portability. The **247002** is a single-pak unit as well, with an added range for extra precision, down to 0.1 mΩ resolution.



Cat. No. 247000

## 100-Ampere Digital Micro-Ohmmeter

For maximum portability in a 100 A unit, the M-400 provides a single module that operates from line power. Its portability makes it ideal for testing around busbars and circuit breakers.

A current regulating circuit stabilizes against line voltage, making measurement possible to 0.1 mΩ. Four selectable test currents at 10, 20, 50 and 100 A facilitate a variety of standards conformances, with a short time rating on the high-current outputs making the compact design possible.



## BT51 Low Resistance Ohmmeter

Where economy and simplicity of operation are paramount, the Megger DUCTER BT51 requires only the setting two-position range switch. Ranges of 2 A and 20.00 mA are selectable, with 1 mΩ and 0.01 mΩ resolution, respectively.

The unit operates with a 2 A test current, provides warning indicators, and is supplied with duplex hand spike leads.



## Transformer Ohmmeter

The Transformer Ohmmeter is a line-operated, field-portable unit designed for rapid testing of inductive loads from magnetic windings in transformers, on-load tap-changers, and rotating machinery.

Two independent measuring channels allow simultaneous testing of primary and secondary windings to attenuate circulating current and improve test time tenfold. Dual channels can also speed testing by measuring two phases at a time. Automatic shutdown is triggered by voltage kickback if tap-changer contacts are opened.

A discharge circuit safely discharges the test item upon completion, or if a lead is disconnected or power lost. Test currents of 5, 50 and 500 mA and 5 A provide measurement to 1999 Ω, with resolution down to 0.001 mΩ.

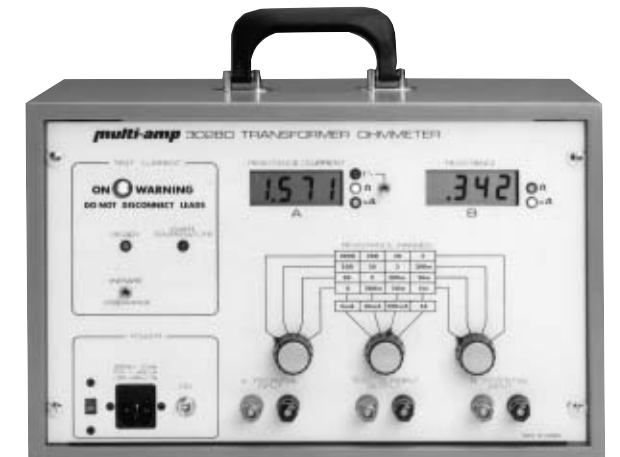

***Your “One Stop” Source for all your electrical test equipment needs***

- Battery Test Equipment
- Cable Fault Locating Equipment
- Circuit Breaker Test Equipment
- Data Communications Test Equipment
- Fiber Optic Test Equipment
- Ground Resistance Test Equipment
- Insulation Power Factor (C&DF) Test Equipment
- Insulation Resistance Test Equipment
- Line Testing Equipment
- Low Resistance Ohmmeters
- Motor & Phase Rotation Test Equipment
- Multimeters
- Oil Test Equipment
- Partial Discharge Test Equipment
- Portable Appliance & Tool Testers
- Power Quality Instruments
- Recloser Test Equipment
- Relay Test Equipment
- T1 Network Test Equipment
- Tachometers & Speed Measuring Instruments
- TDR Test Equipment
- Transformer Test Equipment
- Transmission Impairment Test Equipment
- Watthour Meter Test Equipment
- STATES® Terminal Blocks & Test Switches
- Professional Hands-On Technical and Safety Training Programs

Megger is a world leading manufacturer and supplier of test and measurement instruments used within the electric power, building wiring and telecommunication industries.

With research, engineering and manufacturing facilities in the USA and UK, combined with sales and technical support in most countries, Megger is uniquely placed to meet the needs of its customers worldwide.

For more information about Megger and its diversified line of test and measurement instruments:

**Call:** 1-800-723-2861 - USA

1-800-297-9688 - Canada

1-214-333-3201 - Outside the USA and Canada

**Fax:** 1-214-331-7379

**Email:** [ussales@megger.com](mailto:ussales@megger.com)

**Or go to our website:** [www.megger.com](http://www.megger.com)

**Authors:**

Peter E. Langan

Jeffrey R. Jowett

S. Graeme Thomson

David O. Jones

With sales offices and authorized distributors in most countries, Megger can provide a unique local service for the electrical and communications industries across a complete range of test and measurement instruments. Contact Megger today for expert assistance.

Avec des bureaux de vente et de distributeurs autorisés dans la plupart des pays, Megger peut fournir un service local unique pour les industries spécialisées dans l'électricité et la communication à travers une gamme complète d'instruments d'essai et de mesure. N'hésitez pas à contacter Megger dès aujourd'hui pour une assistance spécialisée.

Gracias a las oficinas de ventas y de distribución autorizadas en la mayoría parte de los países, Megger puede proporcionar a un servicio local único a las industrias especializadas en eléctrica y comunicación a través de una gama completa de los de instrumentos de prueba y medida. No vacilan en contactar Megger a partir de hoy para la asistencia especializada.

Mit Verkaufsbüros und autorisierten Distributoren in vielen Ländern bietet Megger einen einzigartigen Service an Elektrischen- und Kommunikations- Prüf- und Messgeräten. Für Fachbetreuung setzen Sie sich jetzt gleich mit Megger in Verbindung.



Megger Pty Limited  
PO Box 118 Cherrybrook  
SYDNEY  
NSW 2126  
AUSTRALIA  
T +61 (0)2 9875 4765  
F +61 (0)2 9875 1094  
E [ausales@megger.com](mailto:ausales@megger.com)

Megger  
PO Box 15777  
Kingdom of BAHRAIN  
T +973 411311  
F +973 413399  
E [mesales@megger.com](mailto:mesales@megger.com)

Megger Limited  
110 Milner Avenue Unit 1  
Scarborough Ontario M1S 3R2  
CANADA  
T 1 800 297 9688 (Canada only)  
T +1 416 298 6770  
F +1 416 298 0848  
E [casales@megger.com](mailto:casales@megger.com)

Megger  
MBE No 393  
C/Modesto Lafuente 58  
28003 Madrid  
ESPAÑA  
T + 44 1304 502100  
F + 44 1304 207342  
E [espana@megger.com](mailto:espana@megger.com)

Megger SARL  
23 rue Eugène Henaff  
ZA du Buisson de la Coudre  
78190 TRAPPES  
FRANCE  
T +01 30 16 08 90  
F +01 34 61 23 77  
E [infos@megger.com](mailto:infos@megger.com)

Megger  
PO Box 12052  
Mumbai 400 053  
INDIA  
T +91 22 6315114  
F +91 22 6328004  
E [insales@megger.com](mailto:insales@megger.com)

Megger Limited  
Archcliffe Road Dover  
CT17 9EN  
UK  
T +44 (0) 1304 502100  
F +44 (0) 1304 207342  
E [uksales@megger.com](mailto:uksales@megger.com)

Megger  
4271 Bronze Way  
Dallas TX 75237-1019 USA  
T 1 800 723 2861 (USA only)  
T +1 214 333 3201  
F +1 214 331 7399  
E [ussales@megger.com](mailto:ussales@megger.com)

Megger  
Valley Forge Corporate Center  
2621 Van Buren Avenue  
Norristown PA 19403 USA  
T 1 800 723 2861 (USA only)  
E [ussales@megger.com](mailto:ussales@megger.com)

# Megger

[WWW.MEGGER.COM](http://WWW.MEGGER.COM)